

NOTES, UNLESS OTHERWISE SPECIFIED:

1. RESISTANCE VALUES IN OHMS.
2. CAPACITANCE VALUES IN MICROFARADS.
3. REFERENCE DESIGNATORS USED:
4. ALL 0.1 uF AND 0.01uF CAPACITORS ARE DECOUPLING CAPS UNLESS OTHERWISE NOTED. THEY ARE SHOWN ON THE PAGE WITH THE INTEGRATED CIRCUITS THEY SHOULD BE PLACED NEAR.

5. OBSERVE THE FOLLOWING LAYOUT NOTES:

6. BOARD PROPERTIES

- A. ROUTE TO WITHIN 10% OF MANHATTAN DISTANCE
- B1. General layers 50 +/- 5 OHM MATCHED IMPEDANCE
- B2. USB layer 90 ohm differential
- C. OUTER LAYERS 0.5 OZ CU /W 0.5 OZ AU PLATING
- D. INNER LAYERS 1.0 OZ CU
- E. FR4 BOARD MATERIAL
- F. MINIMUM TRACE WIDTH/SPACING 4 MILS
- G. MINIMUM VIA SIZE 10/19 MIL
- H. LAYER STACKUP:

SCHMATIC CONTENTS

- 01 DAVINCI EVM TITLE SHEET
- 02 DAVINCI EVM BLOCK DIAGRAM
- 03 DAVINCI EMIF INTERFACE
- 04 DAVINCI DDR INTERFACE
- 05 DAVINCI VIDEO INTERFACE
- 06 DAVINCI I/O INTERFACE
- 07 DAVINCI USB & SD/MMC/MS CONTROLLER
- 08 DAVINCI EMULATION & CLOCKS
- 09 DAVINCI POWER PINS
- 10 DAVINCI CONFIGURATION CONTROL/BOOT OPTIONS
- 11 DDR2 MEMORY
- 12 SRAM/NAND FLASH
- 13 NOR FLASH
- 14 EMIF LEVEL SHIFTER
- 15 EMIF CPLD MULTIPLEXER
- 16 SD/MMC/MS CONNECTOR
- 17 SM/xD CONNECTOR
- 18 ATA INTERFACE
- 19 COMPACT FLASH CONNECTOR
- 20 RS232 INTERPACE
- 21 USB 2.0 INTERFACE
- 22 ETHERNET INTERFACE
- 23 TVP5146 LEVEL SHIFTER
- 24 TVP5416 VIDEO DECODER
- 25 VIDEO OUT
- 26 AIC33 AUDIO INTERFACE
- 27 SPDIF OUTPUTS & USER LEDES
- 28 MSP430 & IR INTERFACE
- 29 EMIF EXPANSION CONNECTOR
- 30 VIDEO INPUT/OUTPUT CONNECTORS
- 31 EMAC/GIO & McBSP/SPI & SD CONNECTORS
- 32 VLYNQ CONNECTOR
- 33 DAVINCI EMULATION HEADER
- 34 POWER SUPPLY (3.3V) & SYSTEM RESET LOGIC
- 35 POWER SUPPLY (1.8V & DSP_CORE) & EVM POWER CONNECTOR

REV	DESCRIPTION	DATE	APPROVED
A	Initial schematic ready for layout - Alpha Release	02/17/05	RRP
B	Beta Release	09/27/05	RRP
C	Gamma Release	10/28/05	RRP
D	Production Release	02/18/06	RRP

BASE	I2C ADDRESS TABLE	SHEET
0x50	I2C ROM	6
0x1B	AIC33	26
0x5D	TVP5146	24
0x38	IO EXPANDER 0 (LED)	28
0x39	IO EXPANDER 1 (PLL/USER_SW)	28
0x3A	IO EXPANDER 2 (USB/CD_RESET)	28
0x23	MSP430	28

REVISION STATUS OF SHEETS

REV	A	A	A	A	A	A	A	A	A	A	DATE	BY	DESCRIPTION
31	32	33	34	35							02/17/2005	DWN	R.R.P.
											02/17/2005	CHK	T.W.K.
21	22	23	24	25	26	27	28	29	30		02/17/2005	ENGR	R.R.P.
A	A	A	A	B	A	B	B	B	A		02/17/2005	ENGR-MGR	R.R.P.
11	12	13	14	15	16	17	18	19	20		03/01/2004	CA	C.M.D.
D	A	B	A	B	A	B	B	A	A	NEXT ASSY USED ON	02/17/2005	MFG	R.R.P.
1	2	3	4	5	6	7	8	9	10	APPLICATION	02/17/2005	RLSE	R.R.P.

SPECTRUM DIGITAL INCORPORATED			
Title: DAVINCI EVALUATION MODULE			
Page Contents: Title Block			
Size: B	DWG NO	508162-0001	Revision: D
Date: Wednesday, April 19, 2006			Sheet 1 of 35

Power Supply (3.3V)
& System Reset Logic
SH:34

Power Supply (1.8V & DSP Core)
& DC #7 Connector
SH:35

Config Control &
EM_CS2 Select
SH:10

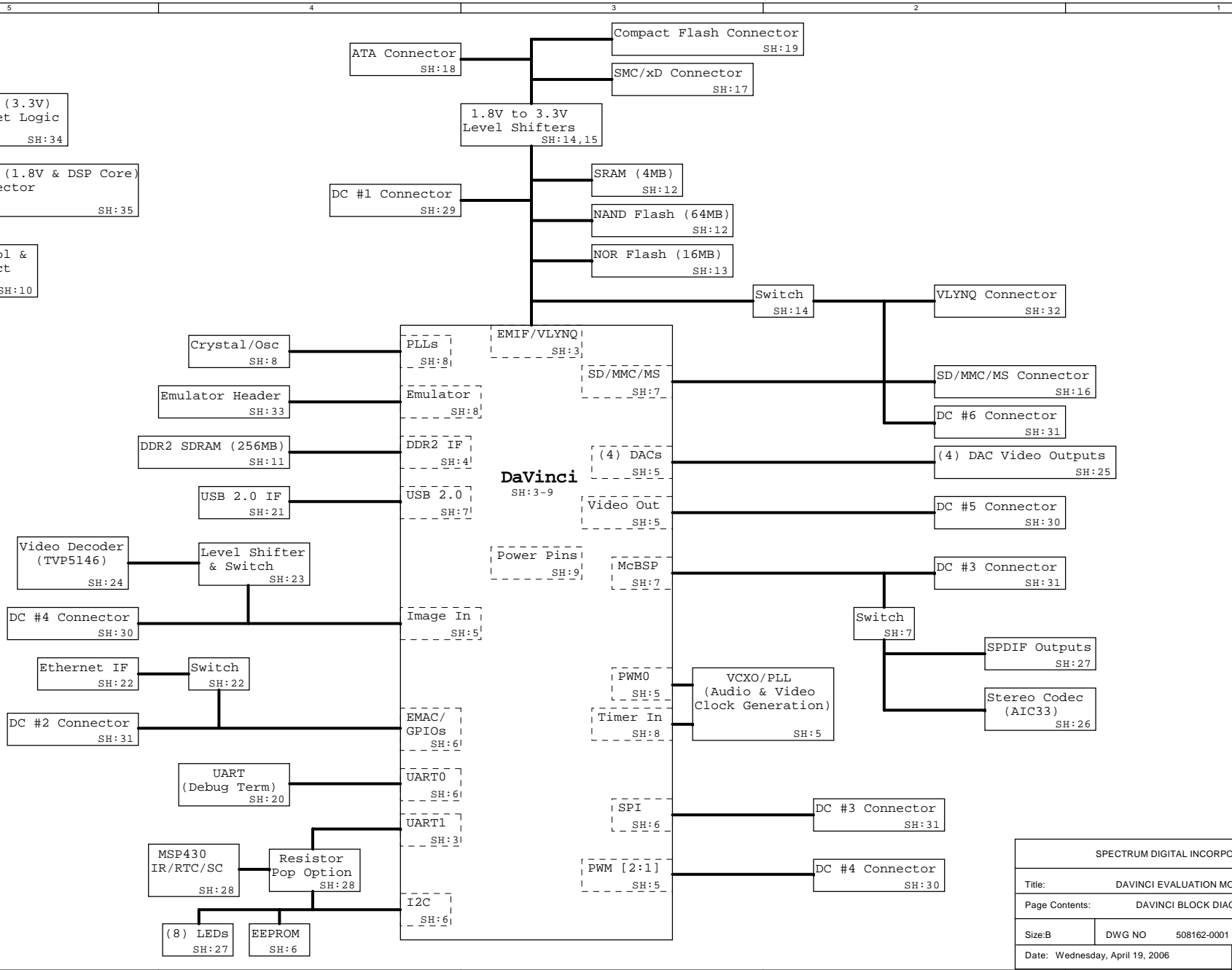

SPECTRUM DIGITAL INCORPORATED			
Title: DAVINCI EVALUATION MODULE			
Page Contents: DAVINCI BLOCK DIAGRAM			
Size: B	DWG NO	508162-0001	Revision: A
Date: Wednesday, April 19, 2006			Sheet 2 of 35

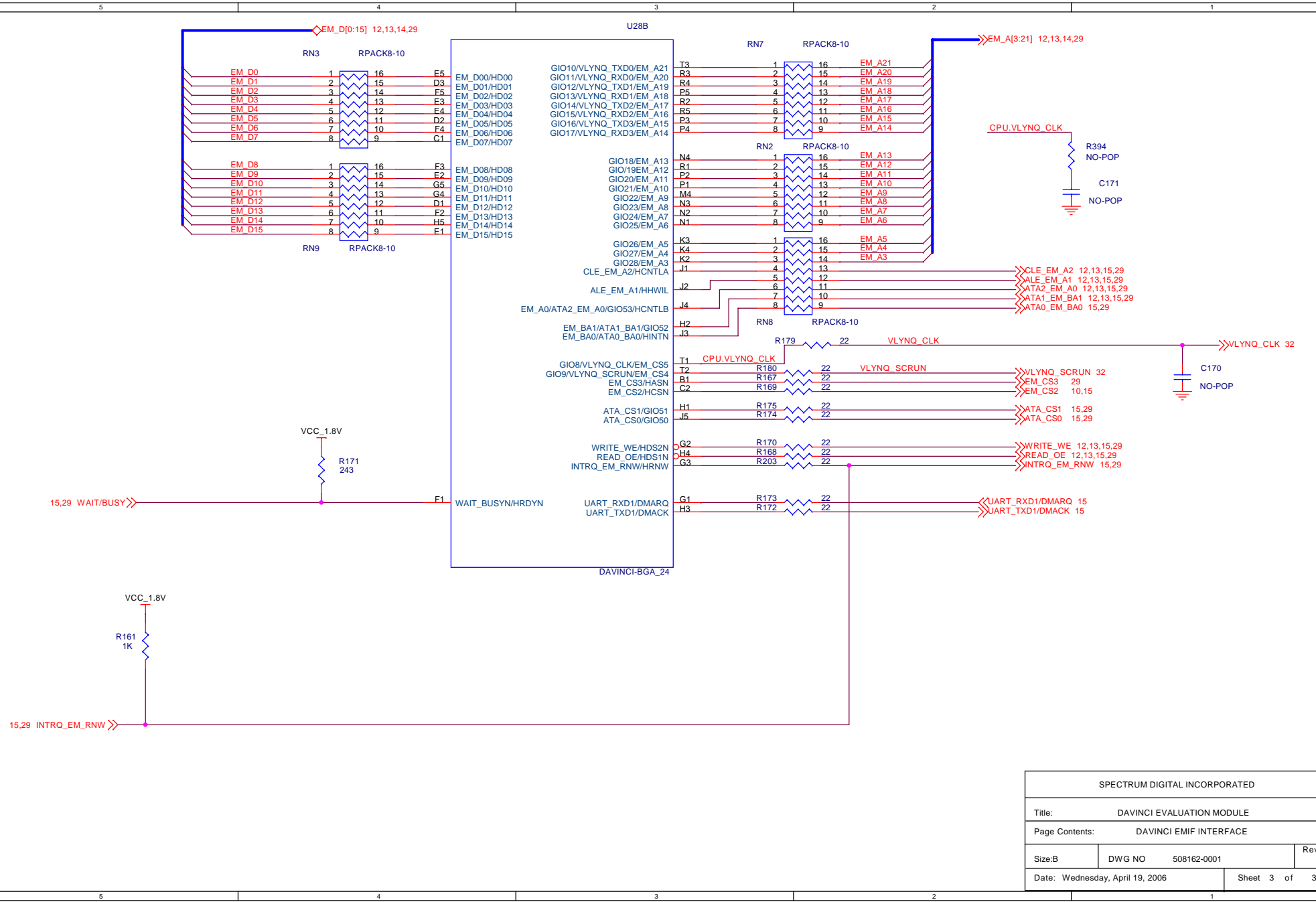

SPECTRUM DIGITAL INCORPORATED			
Title: DAVINCI EVALUATION MODULE			
Page Contents: DAVINCI EMIF INTERFACE			
Size: B	DWG NO	508162-0001	Revision: B
Date: Wednesday, April 19, 2006			Sheet 3 of 35

11 DDR_D[0:31]

DDR_A[0:12] 11

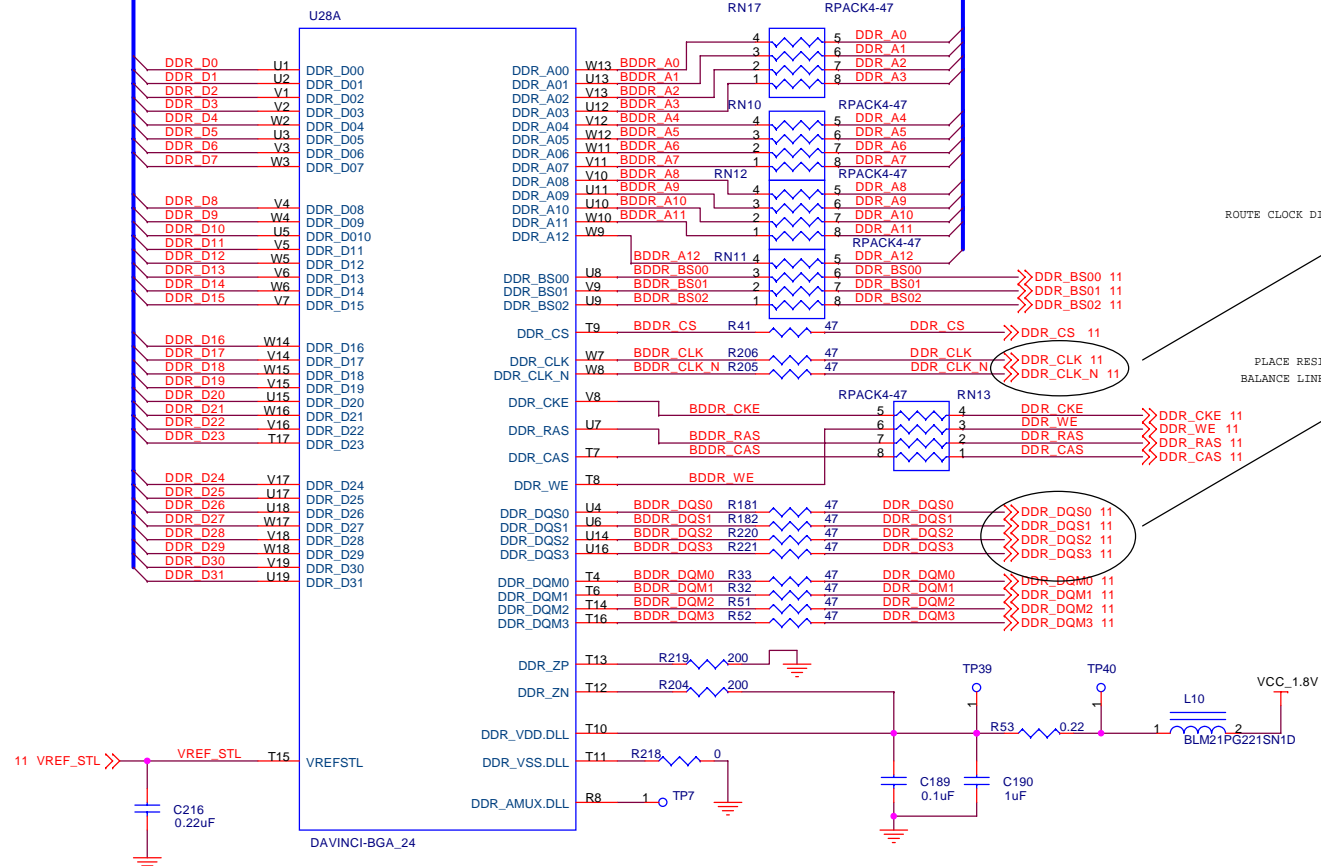

ROUTE CLOCK DIFFERENTIAL WITH 15 MIL SPACING BETWEEN

PLACE RESISTOR BY DATA TERMINATOR PINS
BALANCE LINE LENGTHS WITH DATA BYTES LENGTHS

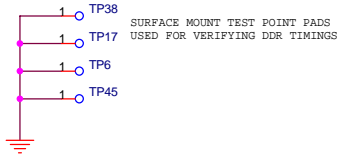

SPECTRUM DIGITAL INCORPORATED			
Title: DAVINCI EVALUATION MODULE			
Page Contents: DAVINCI DDR INTERFACE			
Size: B	DWG NO	508162-0001	Revision: A
Date: Wednesday, April 19, 2006			Sheet 4 of 35

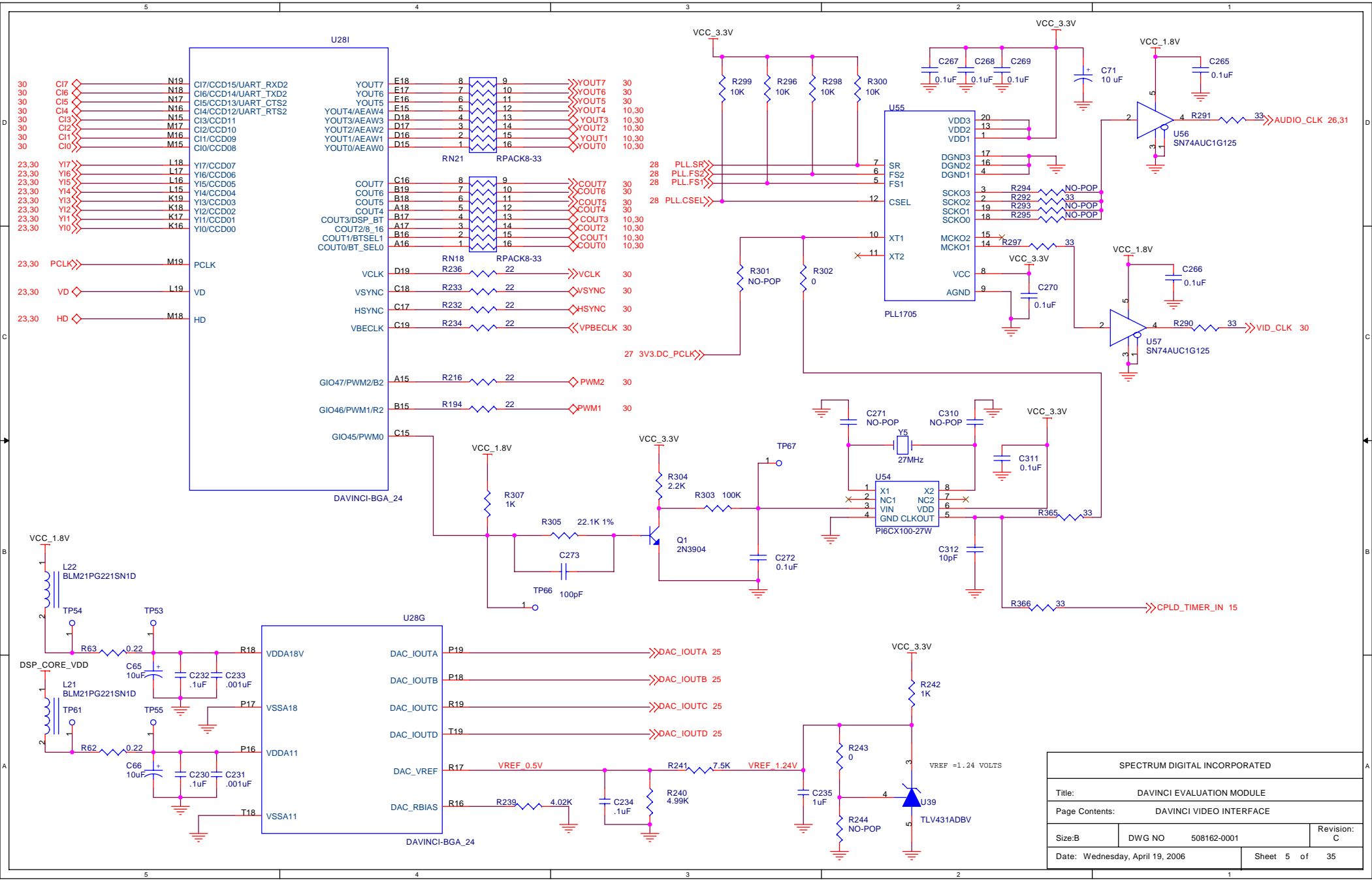

SPECTRUM DIGITAL INCORPORATED			
Title: DAVINCI EVALUATION MODULE			
Page Contents: DAVINCI VIDEO INTERFACE			
Size: B	DWG NO	508162-0001	Revision: C
Date: Wednesday, April 19, 2006		Sheet 5 of 35	

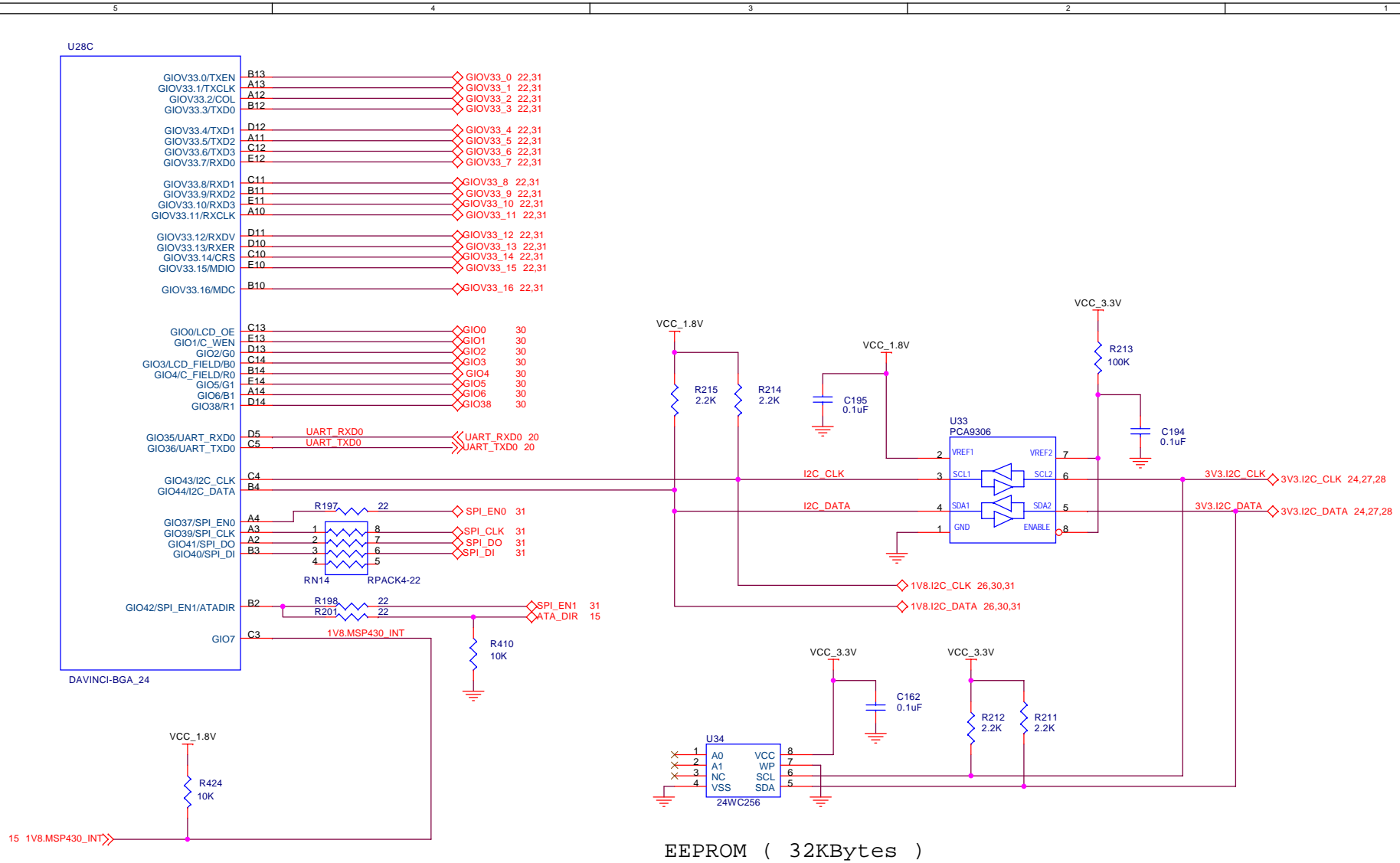

EEPROM (32KBytes)

SPECTRUM DIGITAL INCORPORATED			
Title: DAVINCI EVALUATION MODULE			
Page Contents: DAVINCI I/O INTERFACE			
Size: B	DWG NO	508162-0001	Revision: B
Date: Wednesday, April 19, 2006			Sheet 6 of 35

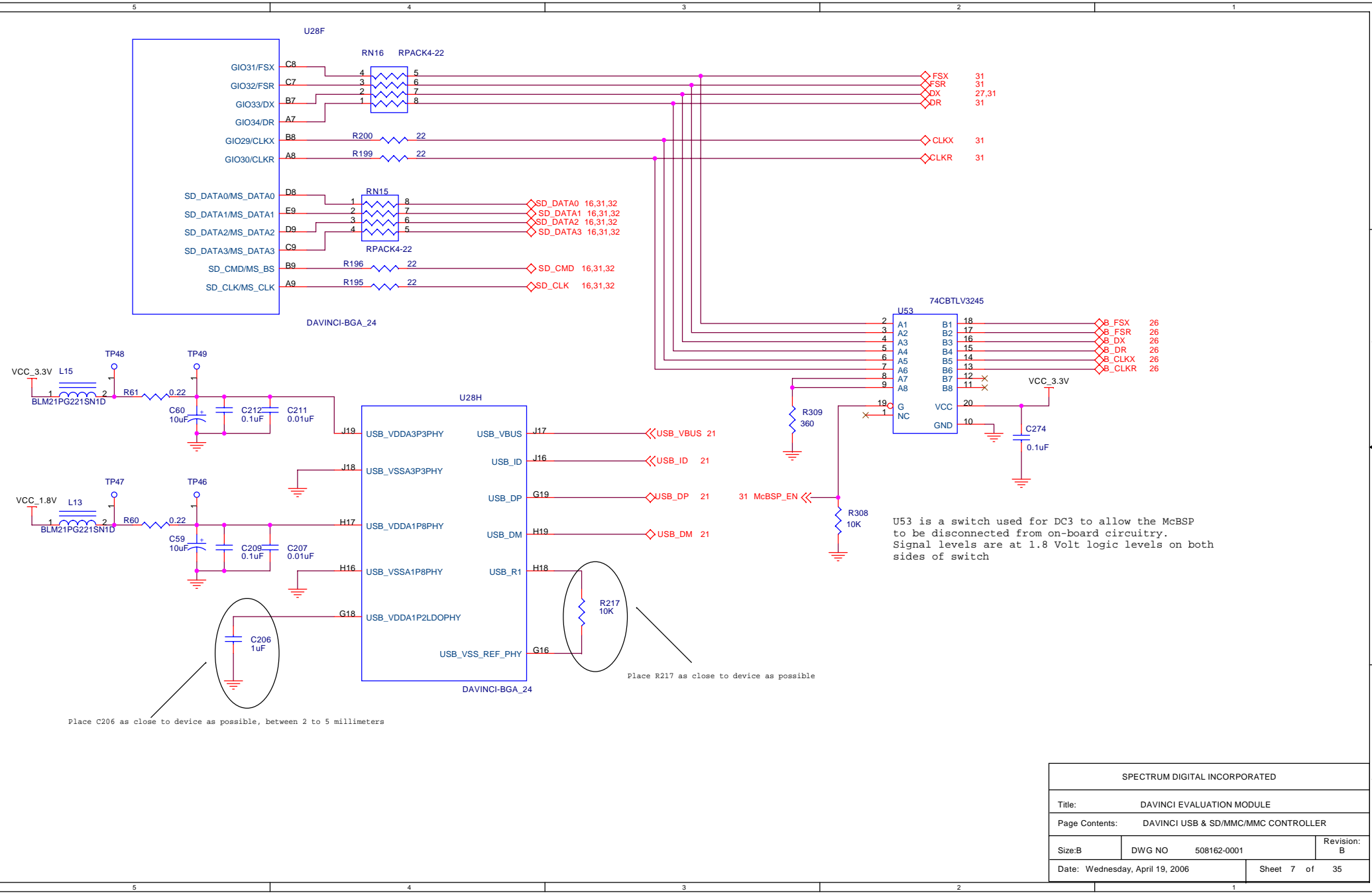

Place C206 as close to device as possible, between 2 to 5 millimeters

Place R217 as close to device as possible

U53 is a switch used for DC3 to allow the McBSP to be disconnected from on-board circuitry. Signal levels are at 1.8 Volt logic levels on both sides of switch

SPECTRUM DIGITAL INCORPORATED			
Title: DAVINCI EVALUATION MODULE			
Page Contents: DAVINCI USB & SD/MMC/MMC CONTROLLER			
Size: B	DWG NO	508162-0001	Revision: B
Date: Wednesday, April 19, 2006			Sheet 7 of 35

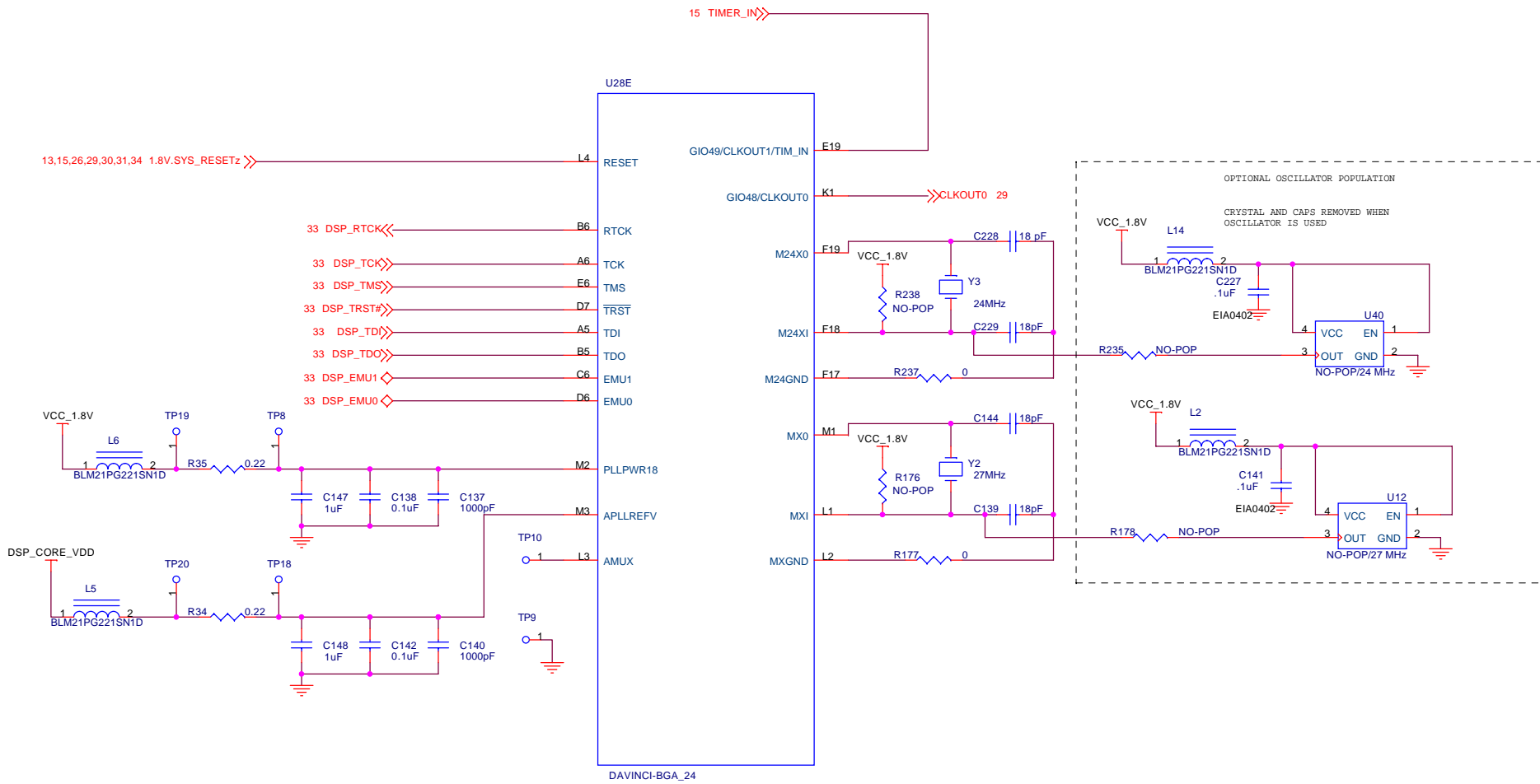

SPECTRUM DIGITAL INCORPORATED			
Title:		DAVINCI EVALUATION MODULE	
Page Contents:		DAVINCI EMULATION & CLOCKS	
Size: B	DWG NO	508162-0001	Revision: B
Date: Wednesday, April 19, 2006		Sheet 8 of 35	

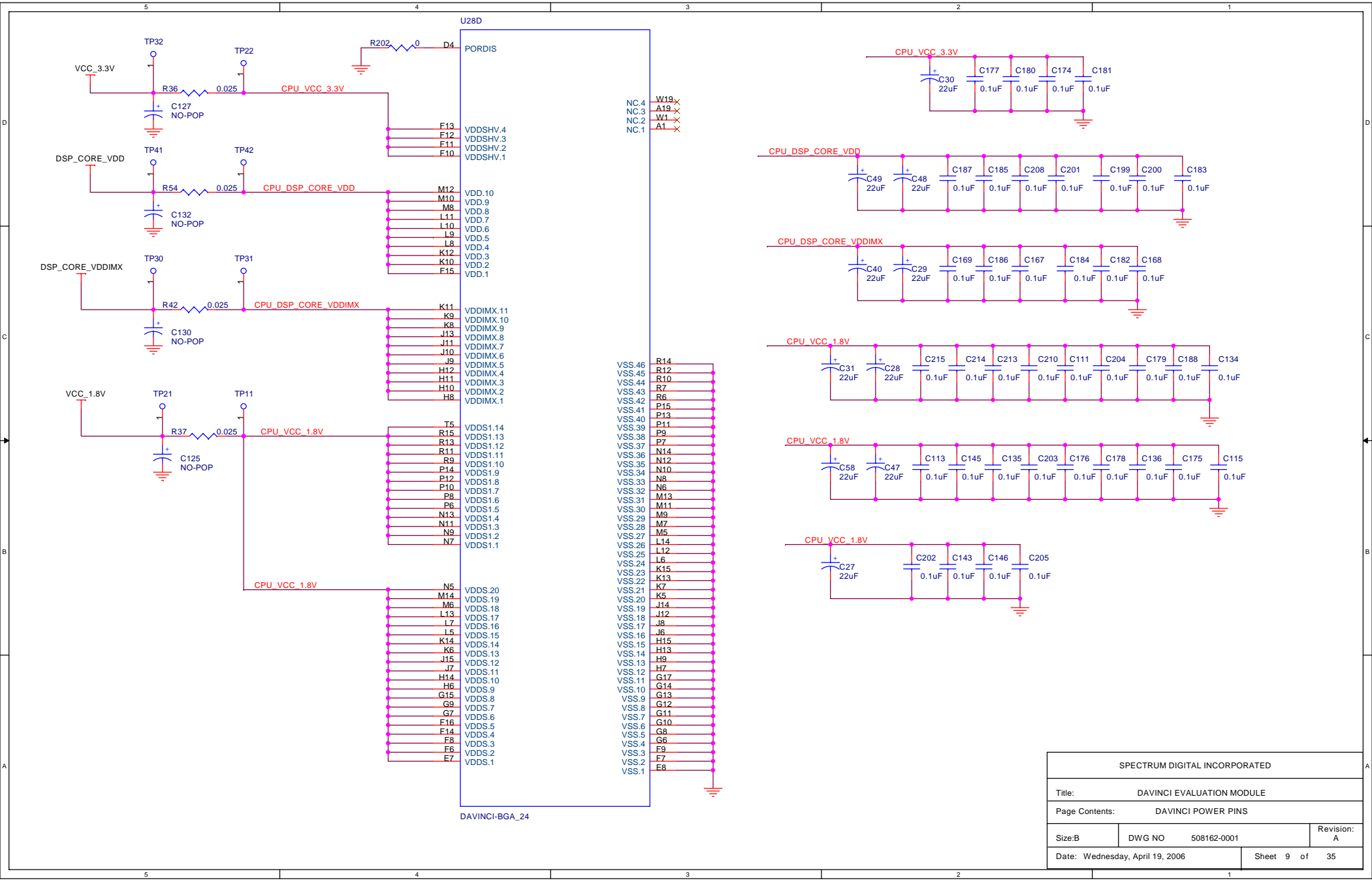

SPECTRUM DIGITAL INCORPORATED			
Title: DAVINCI EVALUATION MODULE			
Page Contents: DAVINCI POWER PINS			
Size: B	DWG NO	508162-0001	Revision: A
Date: Wednesday, April 19, 2006			Sheet 9 of 35

BOOT CONFIGURATION SWITCH			
PINS	MODE	FUNCTION	SWITCH S1
COUT[1:0]	BTSEL[1:0]	Selects ARM Boot Mode	
		Non-secure device	
		00 = Boot from ROM (NAND)	S1-2=XXX S1-1=XXX
		01 = Boot from AEM IF	S1-2=XXX S1-1=XXX
		10 = Boot from ROM (HPI)	S1-2=XXX S1-1=XXX
		11 = Boot from ROM (UART)	S1-2=XXX S1-1=XXX
COUT2	8_16	Selects AEM IF CS2 Bus Width	
		0 = 8-bit	S1-3=XXX
		1 = 16-bit	S1-3=XXX
COUT3	DSP_BT	DSP BOOT	
		0 = ARM boots GEM	S1-4=XXX
		1 = GEM Self-Boots	S1-4=XXX
YOUT[4:0]	AEMW [4:0]	Address Bus Width	
			S1-5=XXX
			S1-6=XXX
			S1-7=XXX
			S1-8=XXX
		S1-9=XXX	

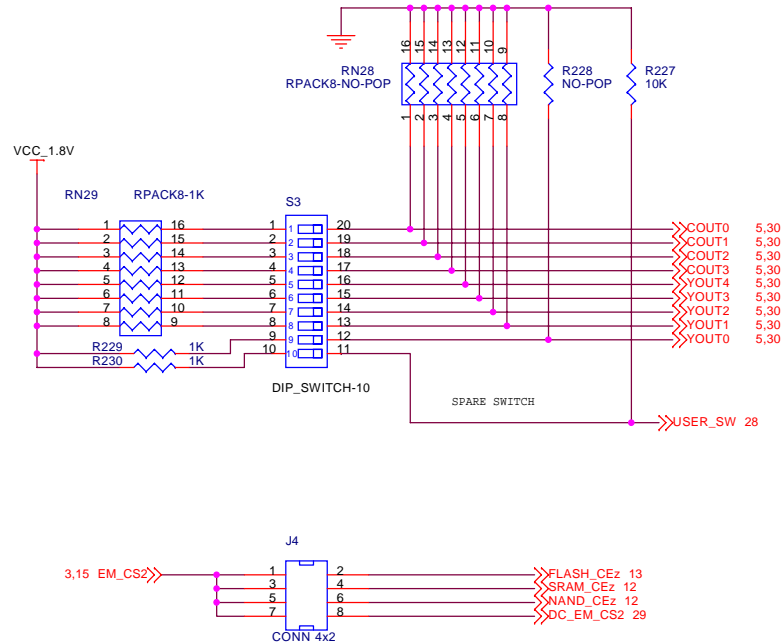

ONLY ONE DEVICE CAN BE SELECTED
AT A TIME AT POWER UP.
TO RECONFIGURE BOARD
POWER DOWN EVM,
CHANGE JUMPER TO DESIRED DEVICE.

SPECTRUM DIGITAL INCORPORATED			
Title: DAVINCI EVALUATION MODULE			
Page Contents: DAVINCI CONFIGURATION CONTROL/BOOT OPTIONS			
Size: B	DWG NO	508162-0001	Revision: A
Date: Wednesday, April 19, 2006			Sheet 10 of 35

4 DDR_A[0:12] >>

4 DDR_BS02 >> DDR_BS02
4 DDR_BS01 >> DDR_BS01
4 DDR_BS00 >> DDR_BS00

4 DDR_CS >> DDR_CS
4 DDR_CAS >> DDR_CAS
4 DDR_RAS >> DDR_RAS
4 DDR_WE >> DDR_WE
4 DDR_CKE >> DDR_CKE

4 DDR_CLK >> DDR_CLK
4 DDR_CLK_N >> DDR_CLK_N

4 DDR_DQS1 >> DDR_DQS1
4 DDR_DQS0 >> DDR_DQS0

4 DDR_DQM1 >> DDR_DQM1
4 DDR_DQM0 >> DDR_DQM0

4 DDR_D[0:31] <<

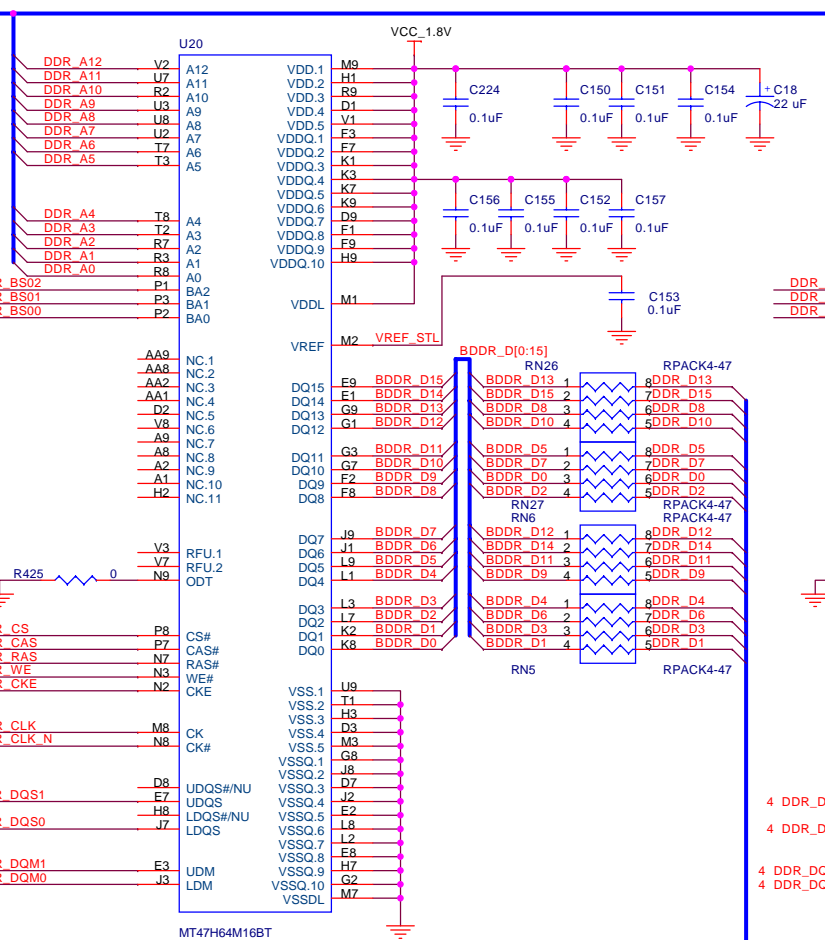

128 MEGABYTES

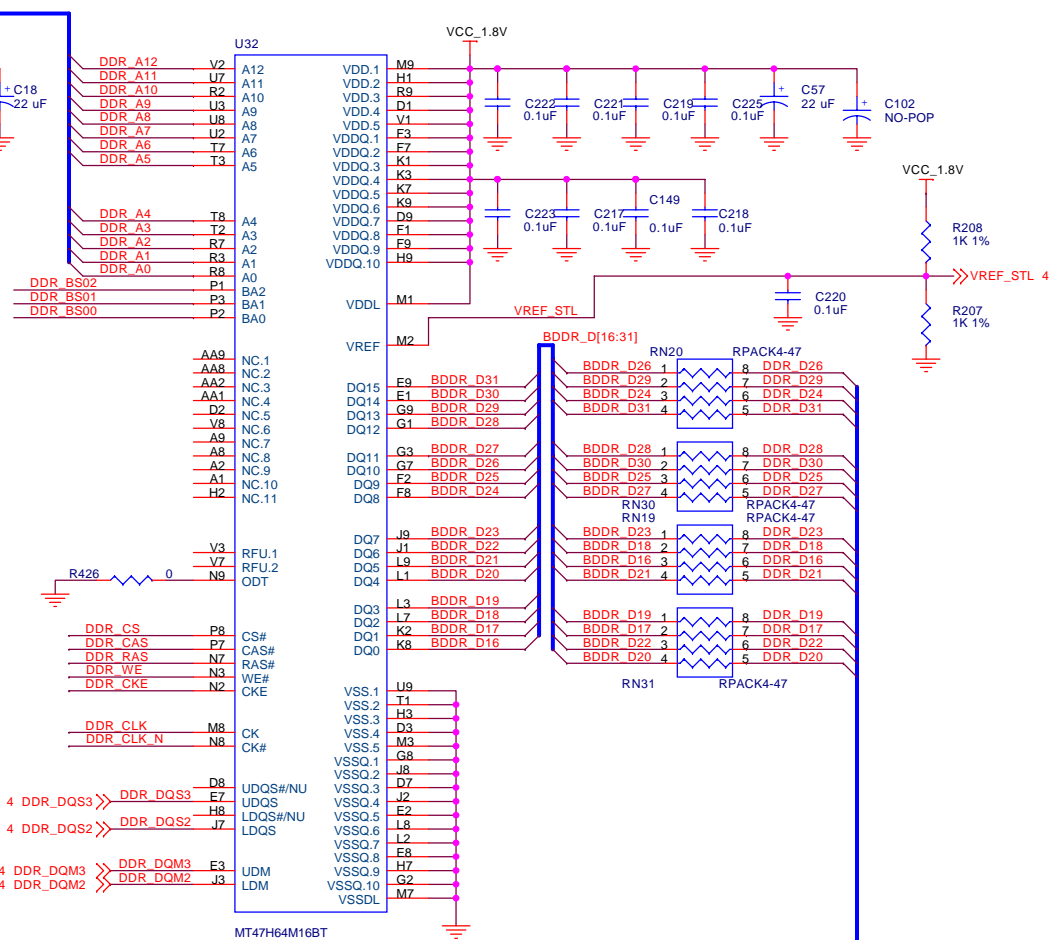

128 MEGABYTES

SPECTRUM DIGITAL INCORPORATED			
Title: DAVINCI EVALUATION MODULE			
Page Contents: DDR2 MEMORY			
Size: B	DWG NO	508162-0001	Revision: A
Date: Wednesday, April 19, 2006			Sheet 11 of 35

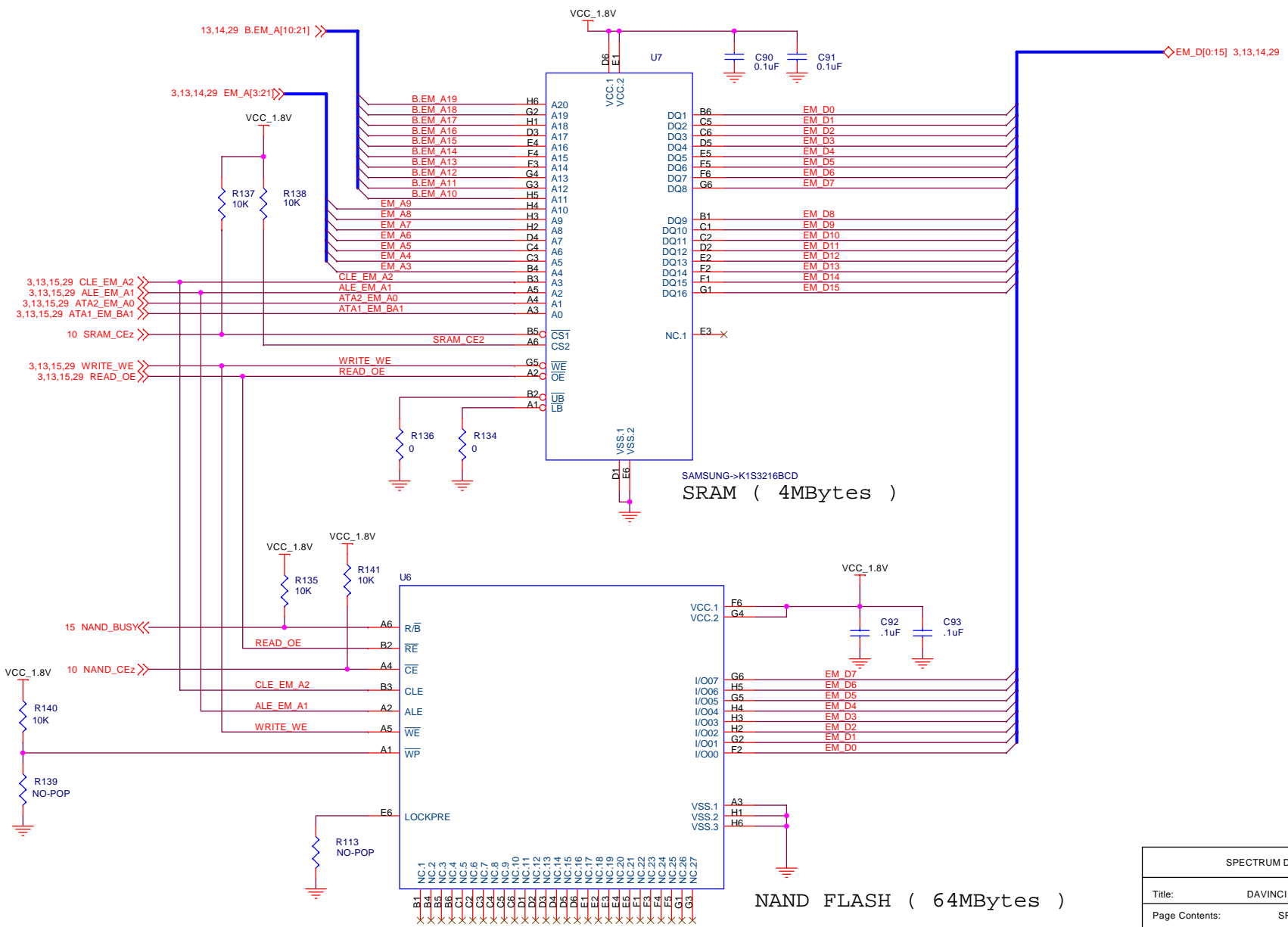

SAMSUNG->K1S3216BCD
SRAM (4MBytes)

SAMSUNG K9K1208/Q/D/U/0C
NAND FLASH (64MBytes)

K9K1G08 supports 128 MEGABYTES

SPECTRUM DIGITAL INCORPORATED			
Title: DAVINCI EVALUATION MODULE			
Page Contents: SRAM/NAND FLASH			
Size: B	DWG NO	508162-0001	Revision: A
Date: Wednesday, April 19, 2006			Sheet 12 of 35

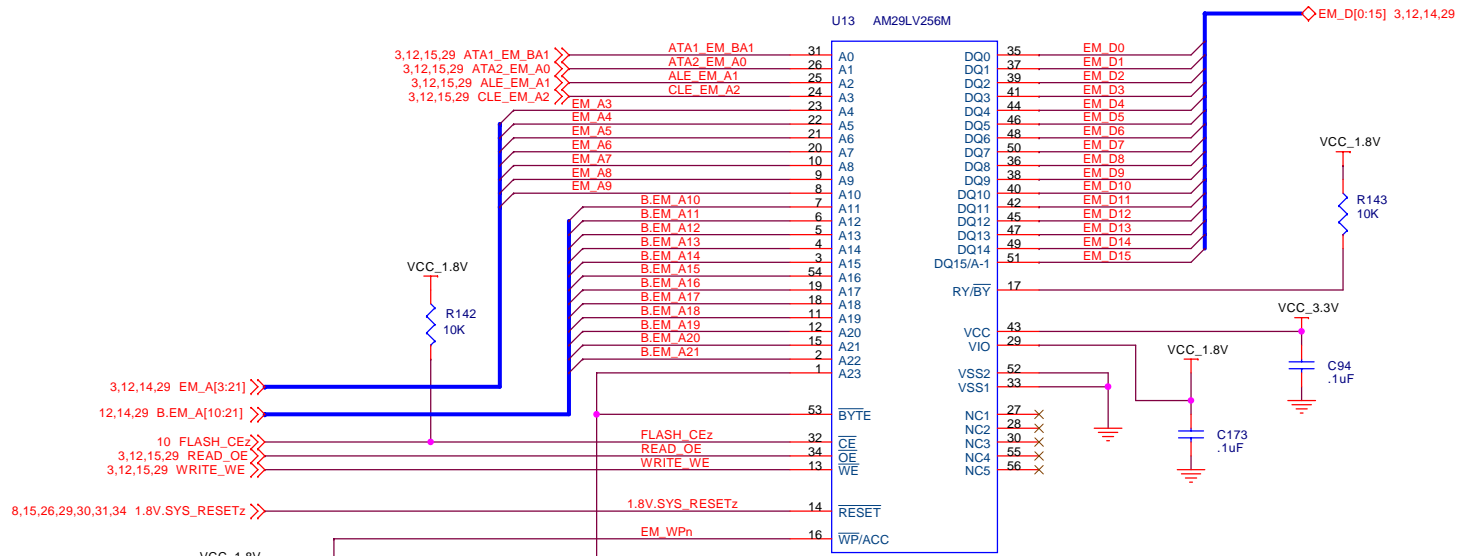

16 MBytes

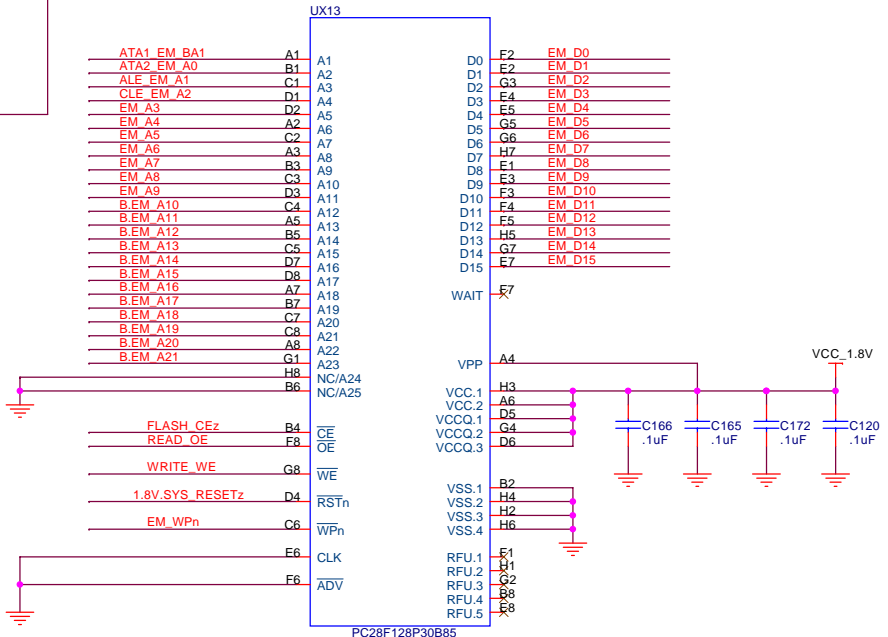

SPECTRUM DIGITAL INCORPORATED			
Title: DAVINCI EVALUATION MODULE			
Page Contents: NOR FLASH			
Size: B	DWG NO	508162-0001	Revision: A
Date: Wednesday, April 19, 2006			Sheet 13 of 35

U11 is a switch used to enable Vlynq functions.
Signal levels are at 1.8 Volt logic levels on both sides of switch

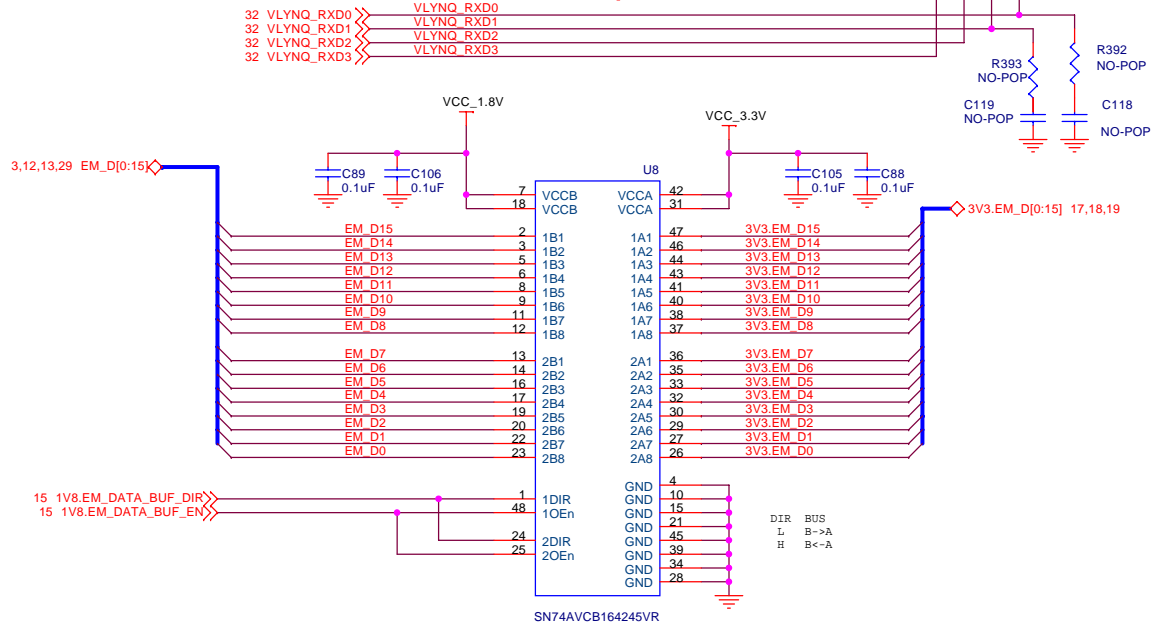
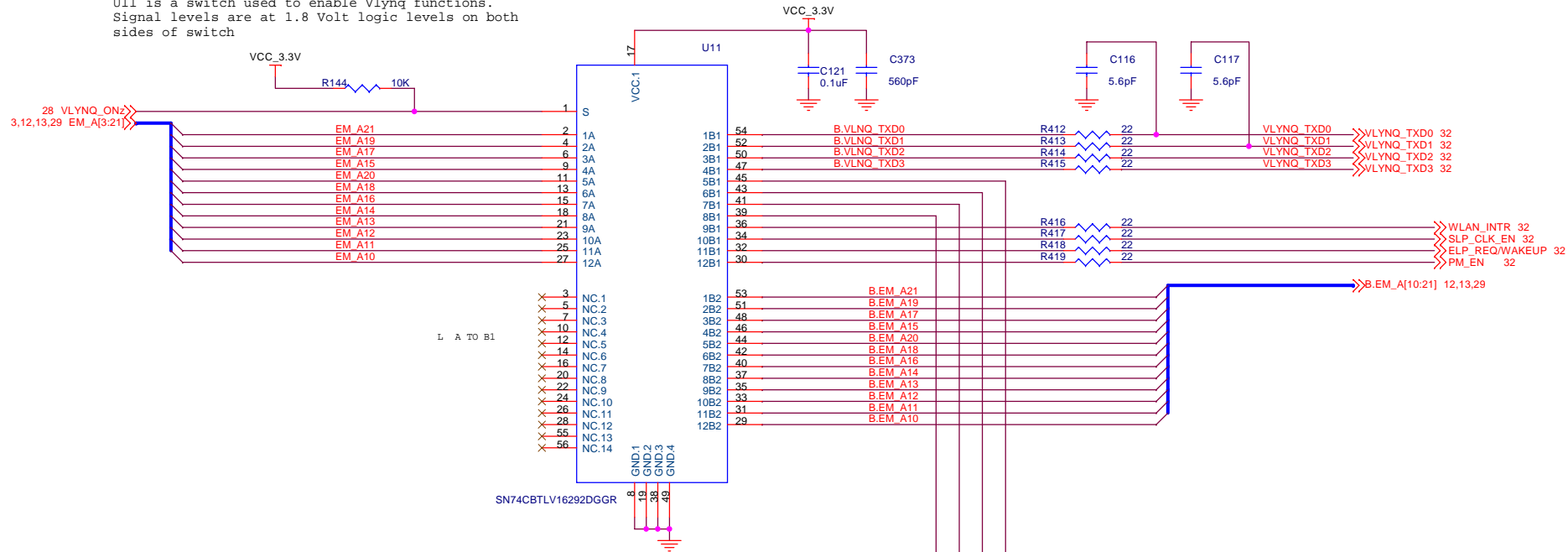

SPECTRUM DIGITAL INCORPORATED			
Title: DAVINCI EVALUATION MODULE			
Page Contents: EMIF LEVEL SHIFTER			
Size: B	DWG NO	508162-0001	Revision: D
Date: Wednesday, April 19, 2006		Sheet 14 of 35	

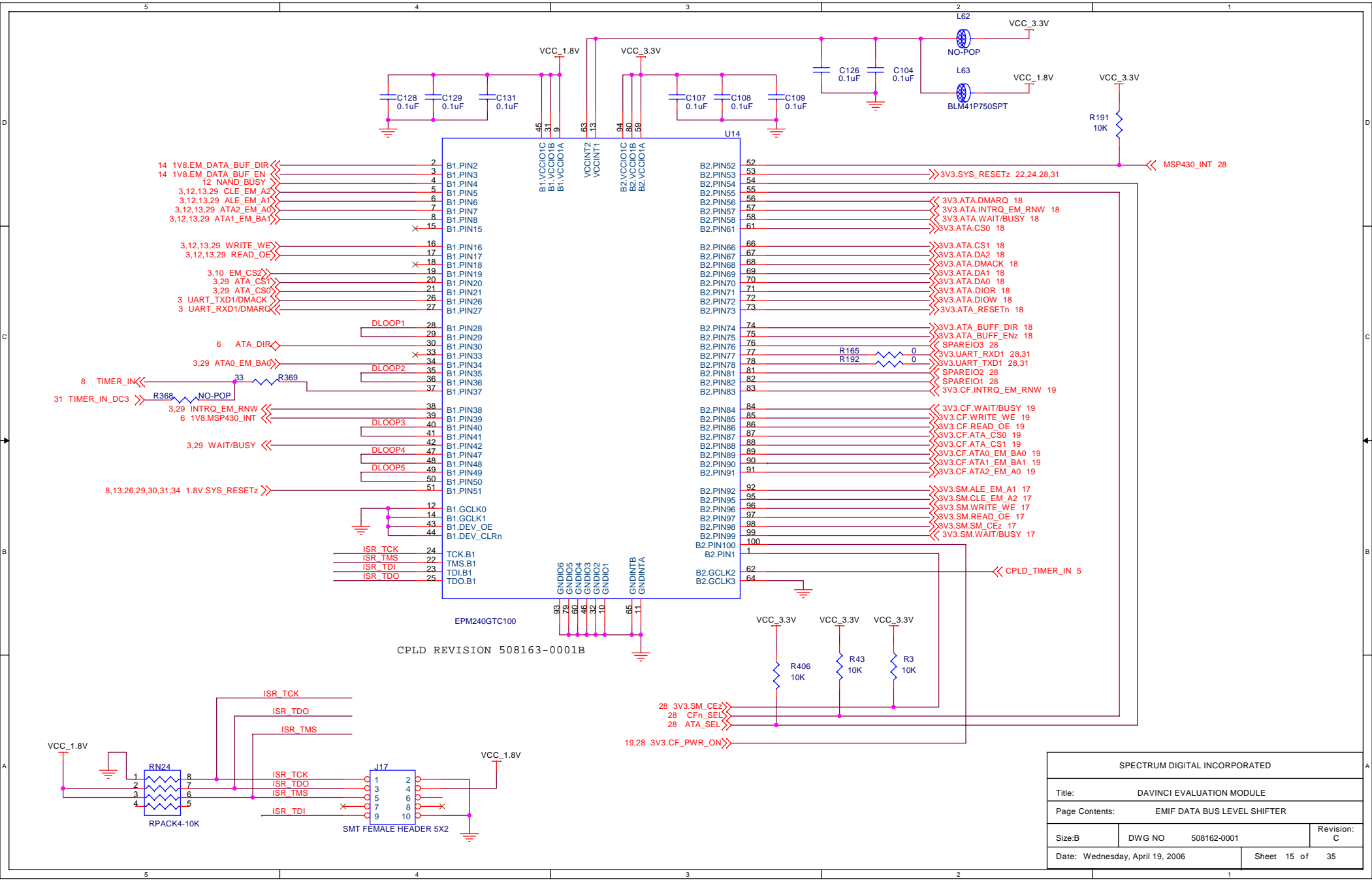

SPECTRUM DIGITAL INCORPORATED			
Title: DAVINCI EVALUATION MODULE			
Page Contents: EMIF DATA BUS LEVEL SHIFTER			
Size: B	DWG NO	508162-0001	Revision: C
Date: Wednesday, April 19, 2006		Sheet 15 of 35	

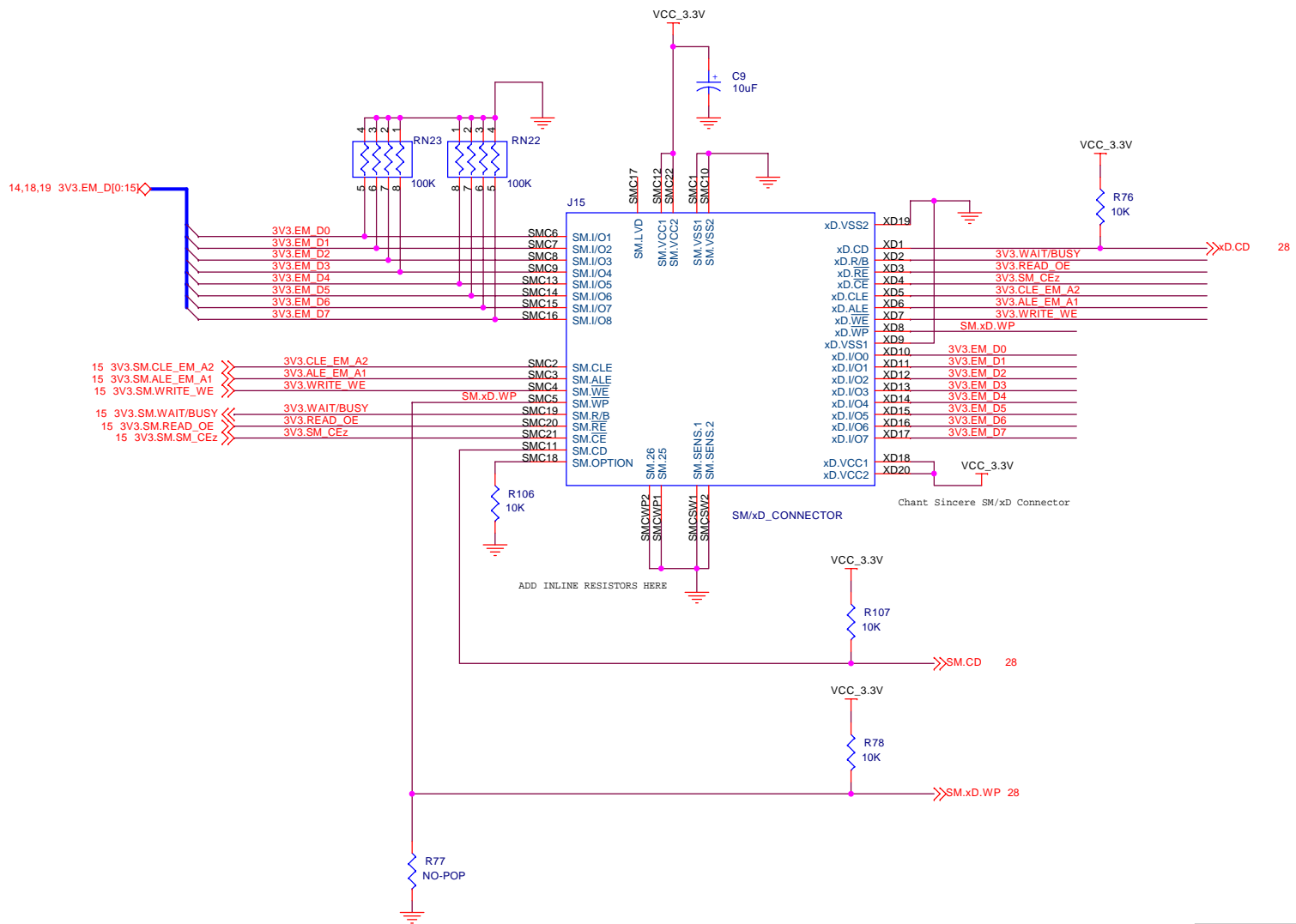

SPECTRUM DIGITAL INCORPORATED			
Title: DAVINCI EVALUATION MODULE			
Page Contents: SM/xD CONNECTOR			
Size: B	DWG NO: 508162-0001	Revision: B	
Date: Wednesday, April 19, 2006		Sheet 17 of 35	

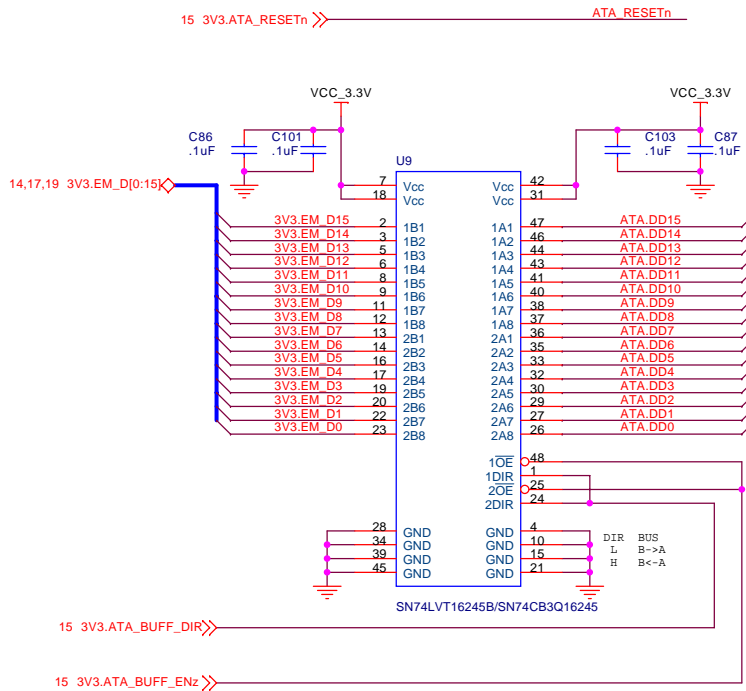

- 15 3V3.ATA.DA0 >> ATA.DA0
- 15 3V3.ATA.DA1 >> ATA.DA1
- 15 3V3.ATA.DA2 >> ATA.DA2
- 15 3V3.ATA.DMACK >> ATA.DMACK
- 15 3V3.ATA.CS0 >> ATA.CS0
- 15 3V3.ATA.CS1 >> ATA.CS1
- 15 3V3.ATA.DIOR >> ATA.DIOR
- 15 3V3.ATA.DIOW >> ATA.DIOW

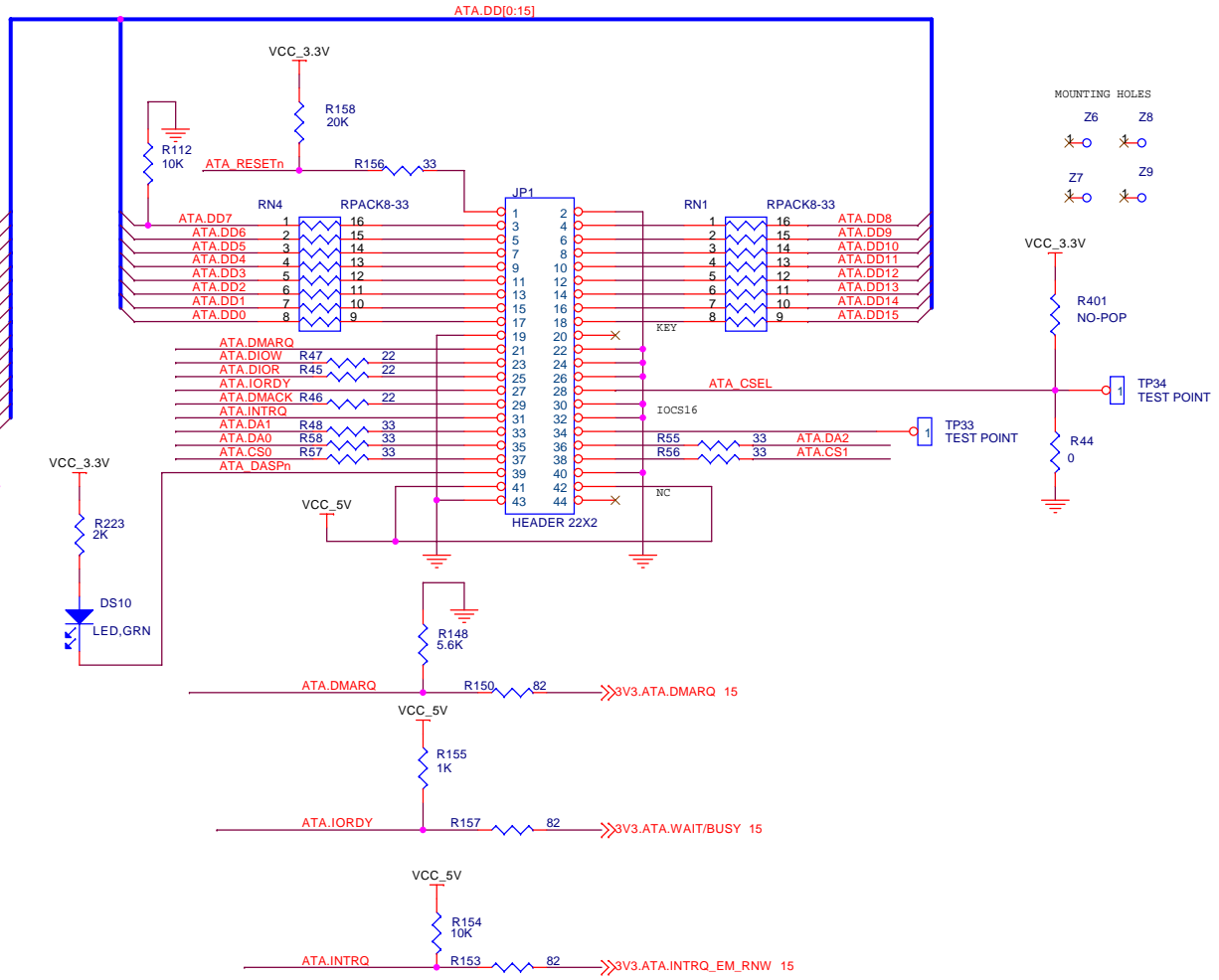

- MOUNTING HOLES
- Z6
 - Z8
 - Z7
 - Z9

SPECTRUM DIGITAL INCORPORATED			
Title: DAVINCI EVALUATION MODULE			
Page Contents: ATA INTERFACE			
Size: B	DWG NO: 508162-0001	Revision: A	
Date: Wednesday, April 19, 2006		Sheet 18 of 35	

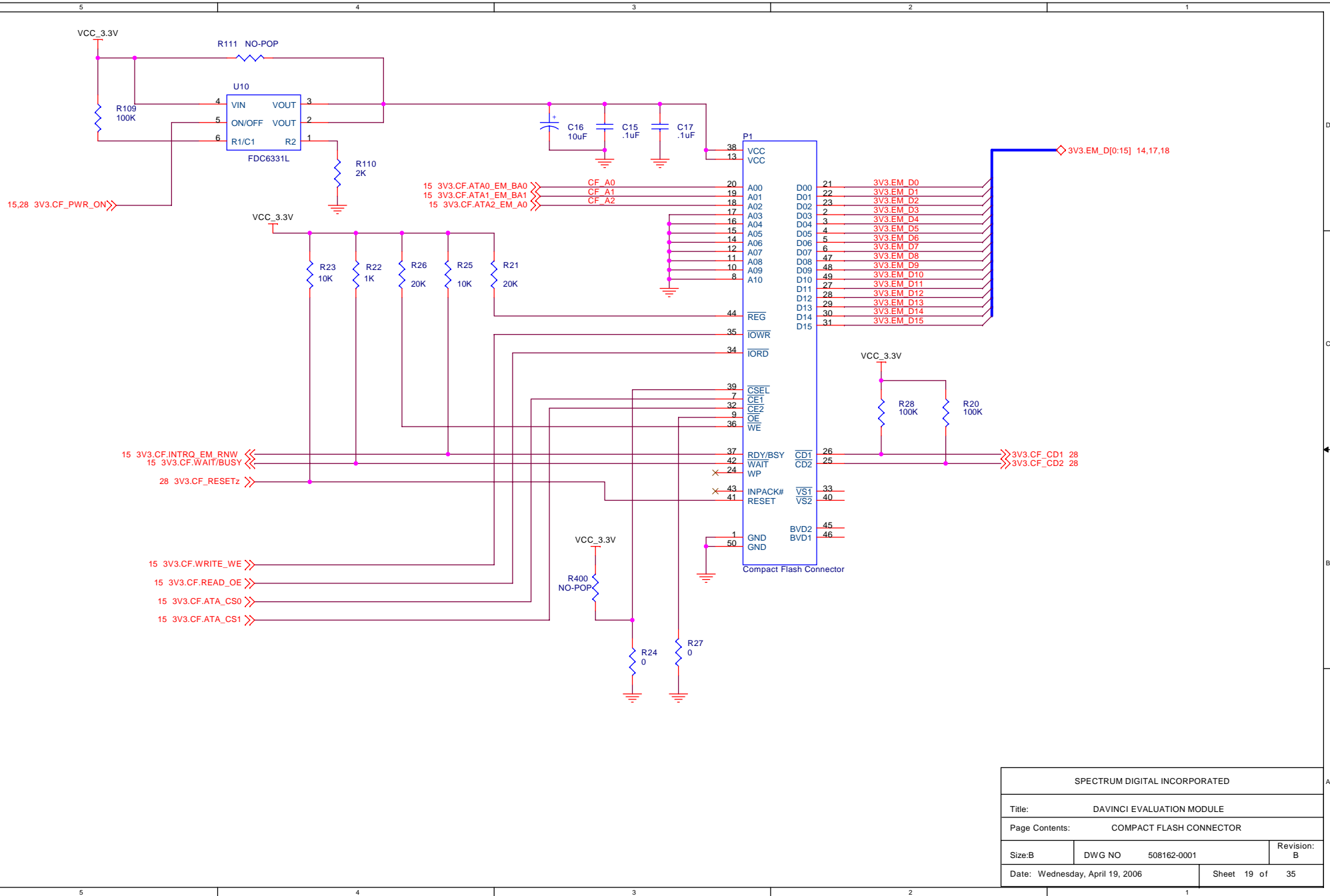

SPECTRUM DIGITAL INCORPORATED			
Title: DAVINCI EVALUATION MODULE			
Page Contents: COMPACT FLASH CONNECTOR			
Size: B	DWG NO	508162-0001	Revision: B
Date: Wednesday, April 19, 2006			Sheet 19 of 35

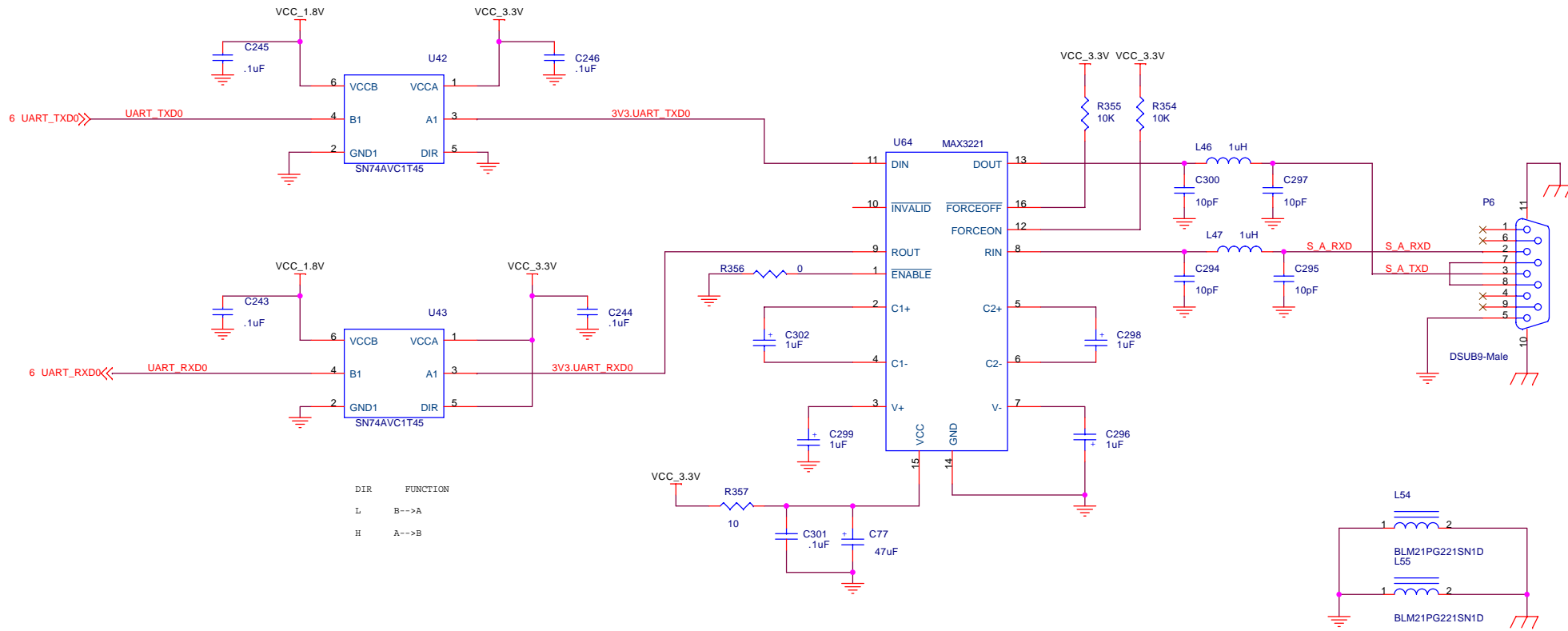

DIR FUNCTION
 L B-->A
 H A-->B

SPECTRUM DIGITAL INCORPORATED			
Title: DAVINCI EVALUATION MODULE			
Page Contents: RS232 INTERFACE			
Size: B	DWG NO	508162-0001	Revision: A
Date: Wednesday, April 19, 2006			Sheet 20 of 35

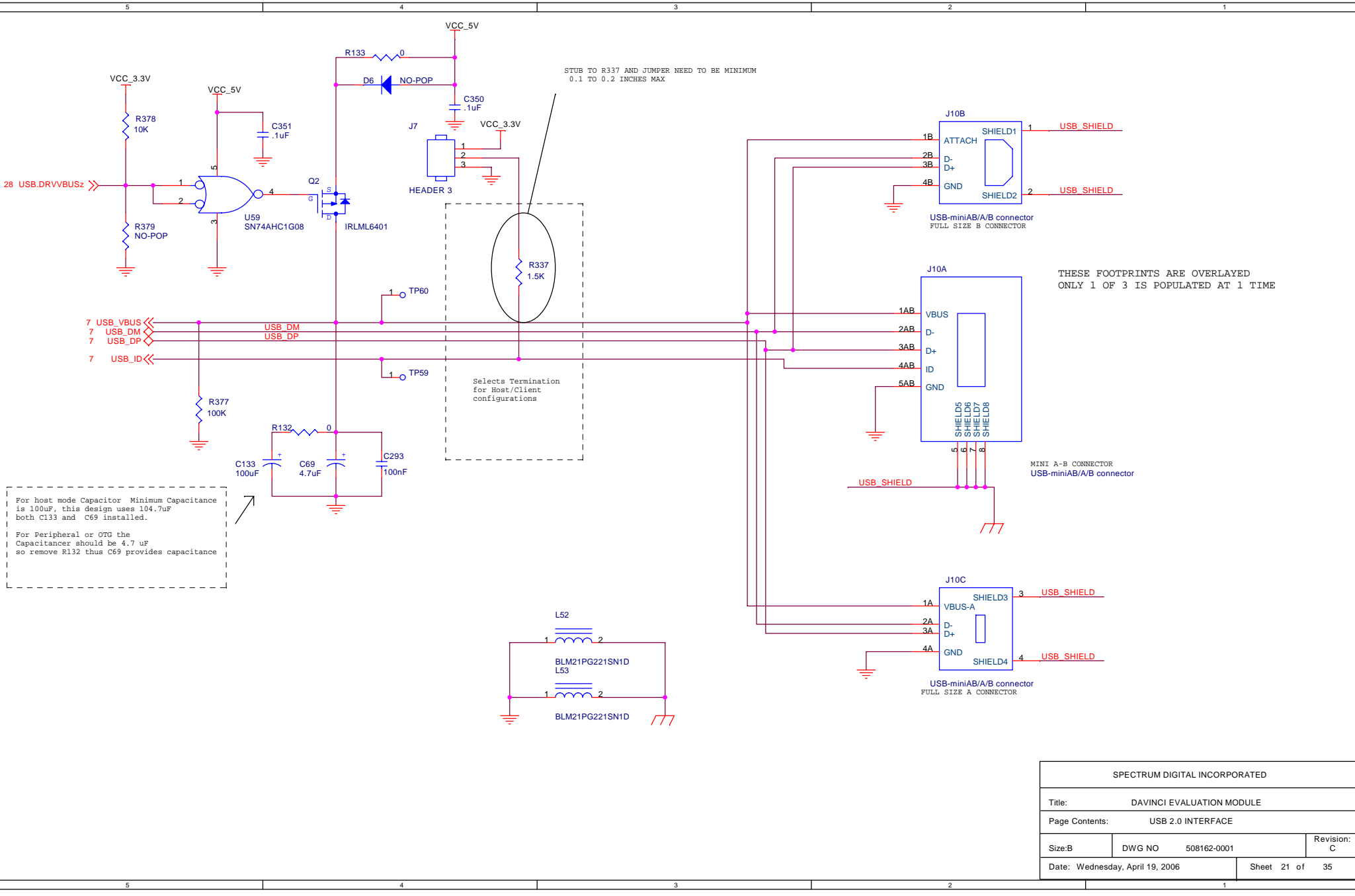

SPECTRUM DIGITAL INCORPORATED			
Title: DAVINCI EVALUATION MODULE			
Page Contents: USB 2.0 INTERFACE			
Size: B	DWG NO	508162-0001	Revision: C
Date: Wednesday, April 19, 2006			Sheet 21 of 35

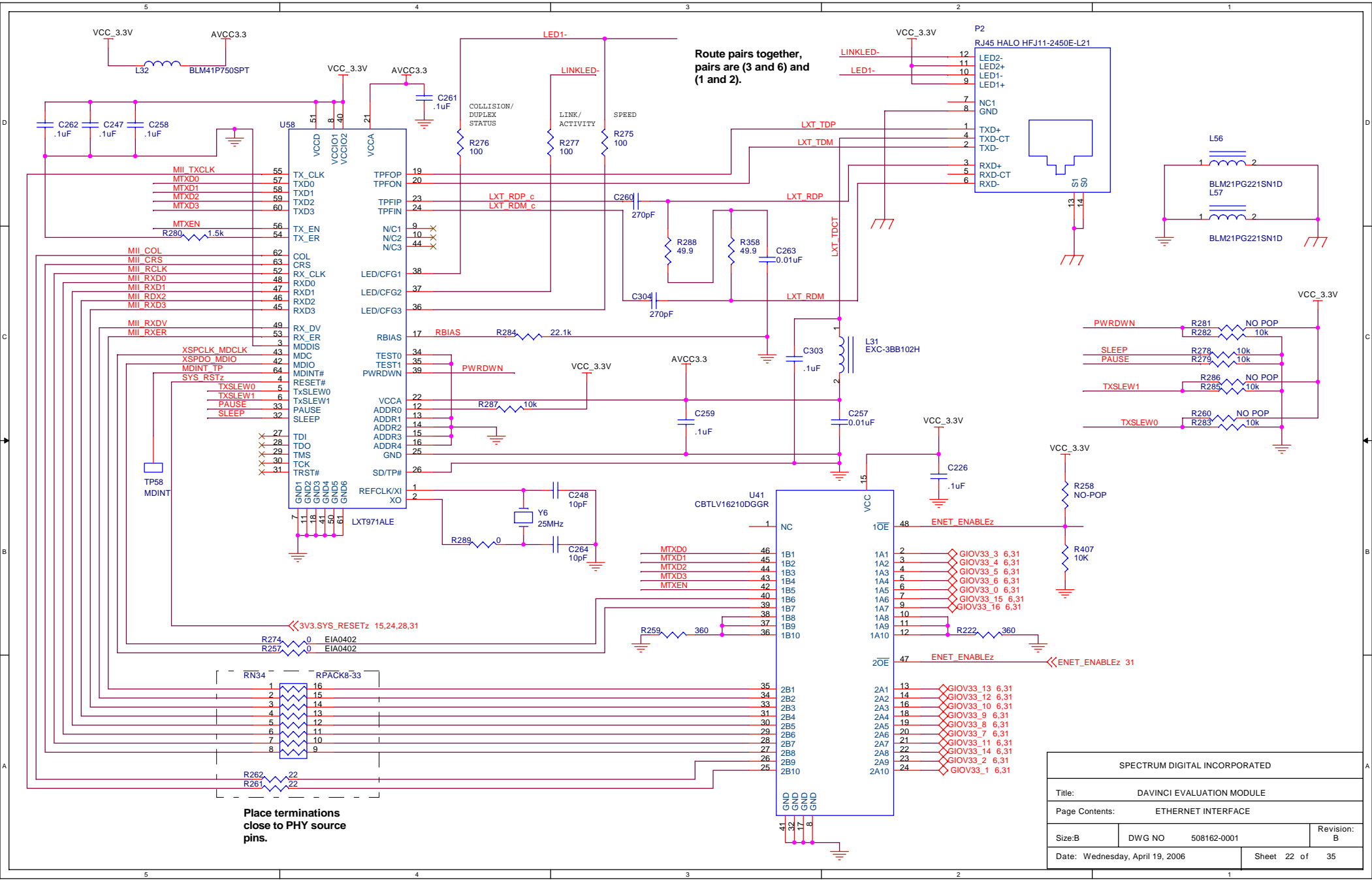

Route pairs together, pairs are (3 and 6) and (1 and 2).

Place terminations close to PHY source pins.

SPECTRUM DIGITAL INCORPORATED			
Title: DAVINCI EVALUATION MODULE			
Page Contents: ETHERNET INTERFACE			
Size: B	DWG NO	508162-0001	Revision: B
Date: Wednesday, April 19, 2006		Sheet 22 of 35	

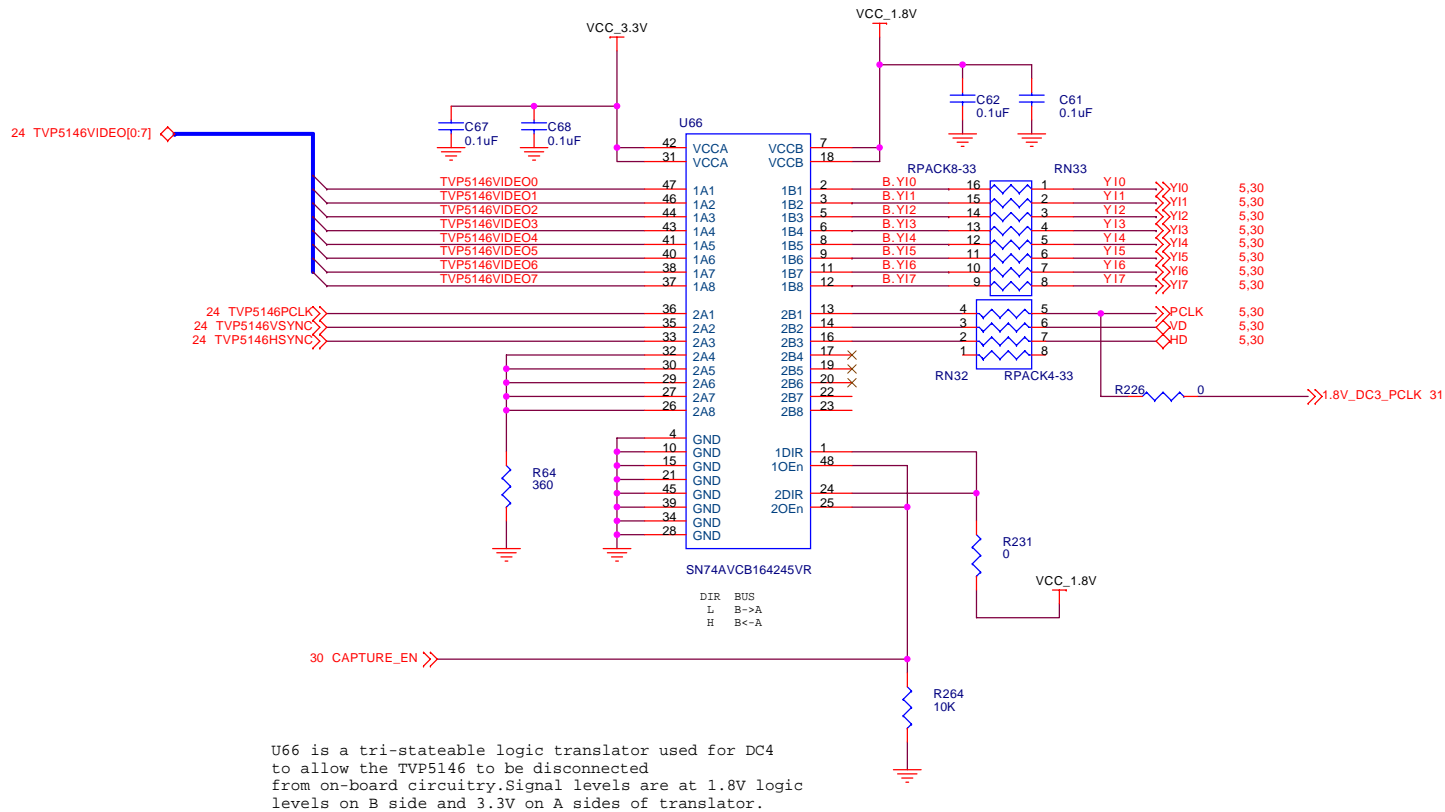

U66 is a tri-stateable logic translator used for DC4 to allow the TVP5146 to be disconnected from on-board circuitry. Signal levels are at 1.8V logic levels on B side and 3.3V on A sides of translator.

SPECTRUM DIGITAL INCORPORATED			
Title: DAVINCI EVALUATION MODULE			
Page Contents: TVP5146 LEVEL SHIFTER			
Size: B	DWG NO	508162-0001	Revision: A
Date: Wednesday, April 19, 2006			Sheet 23 of 35

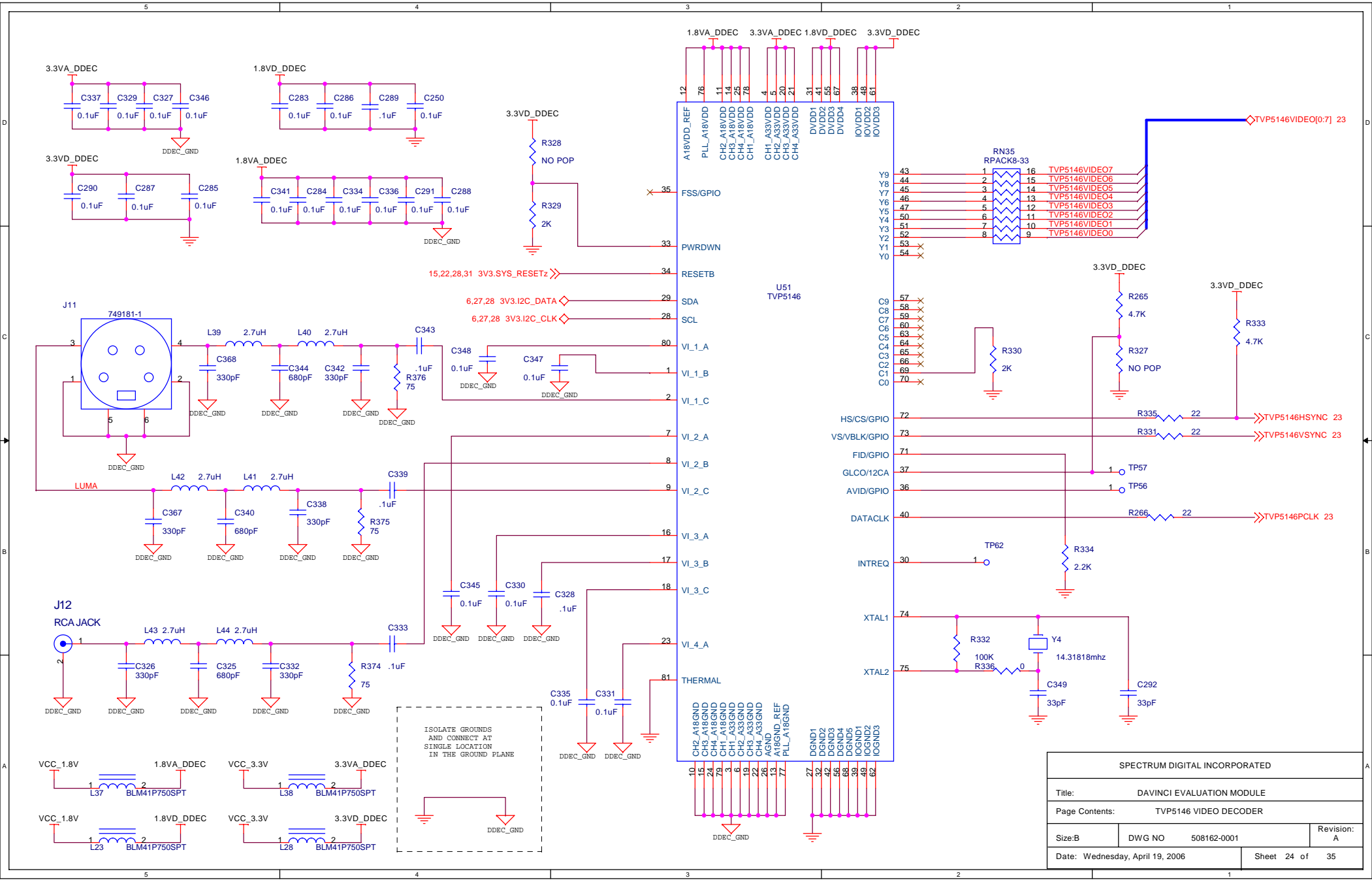

SPECTRUM DIGITAL INCORPORATED			
Title: DAVINCI EVALUATION MODULE			
Page Contents: TVP5146 VIDEO DECODER			
Size: B	DWG NO	508162-0001	Revision: A
Date: Wednesday, April 19, 2006		Sheet 24 of 35	

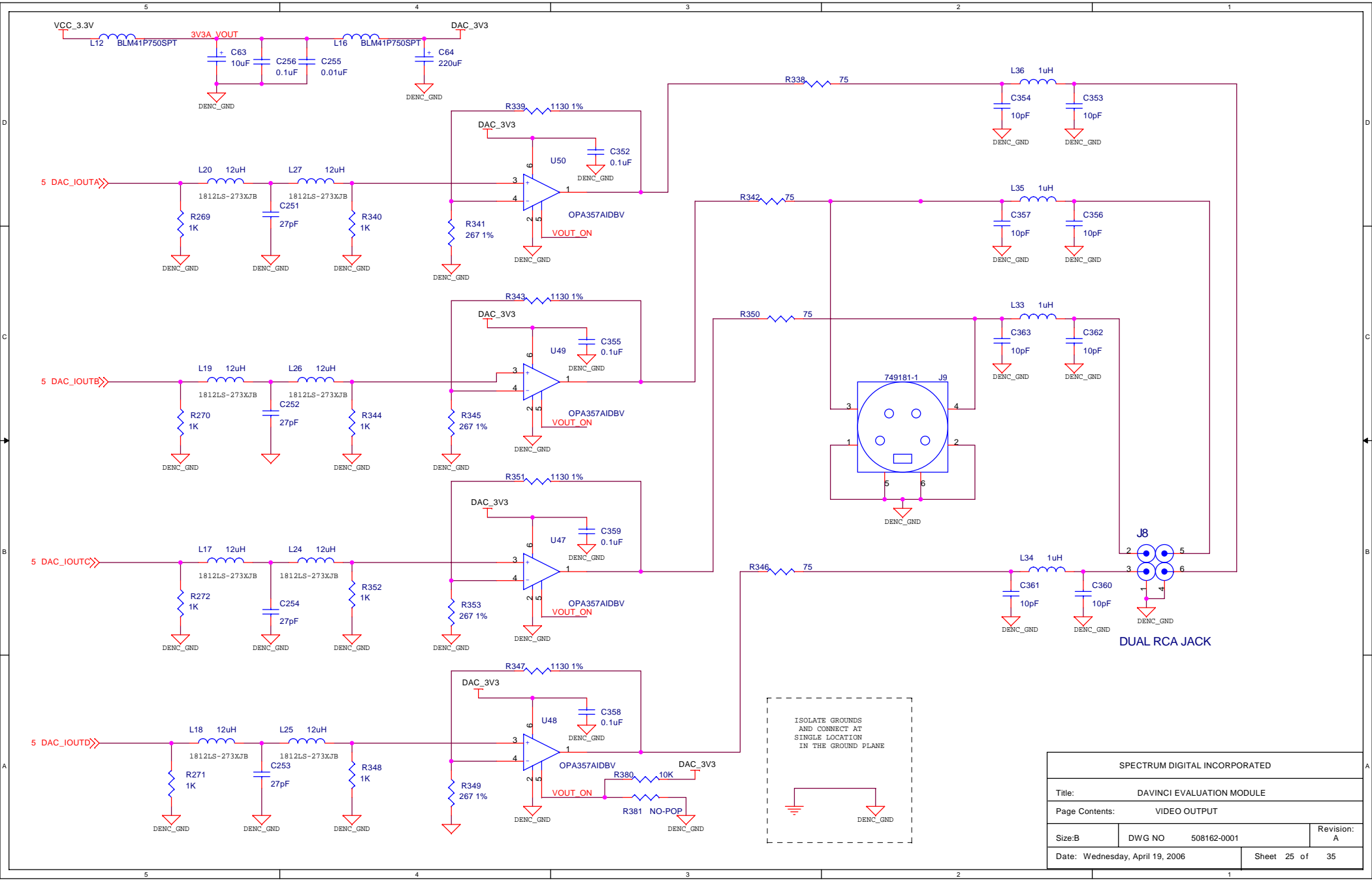

SPECTRUM DIGITAL INCORPORATED			
Title: DAVINCI EVALUATION MODULE			
Page Contents: VIDEO OUTPUT			
Size: B	DWG NO	508162-0001	Revision: A
Date: Wednesday, April 19, 2006			Sheet 25 of 35

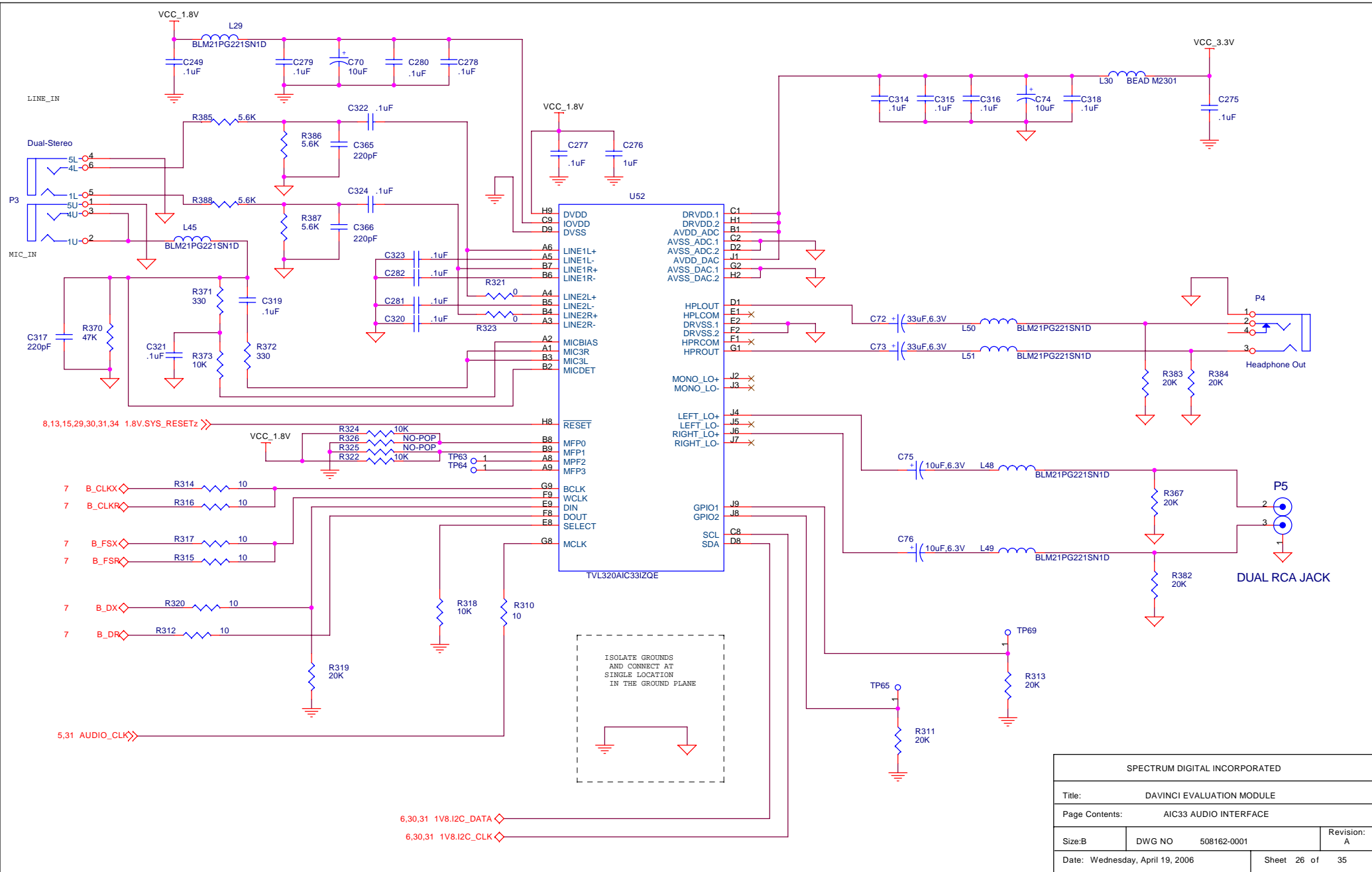

SPECTRUM DIGITAL INCORPORATED		
Title: DAVINCI EVALUATION MODULE		
Page Contents: AIC33 AUDIO INTERFACE		
Size: B	DWG NO: 508162-0001	Revision: A
Date: Wednesday, April 19, 2006	Sheet 26 of 35	

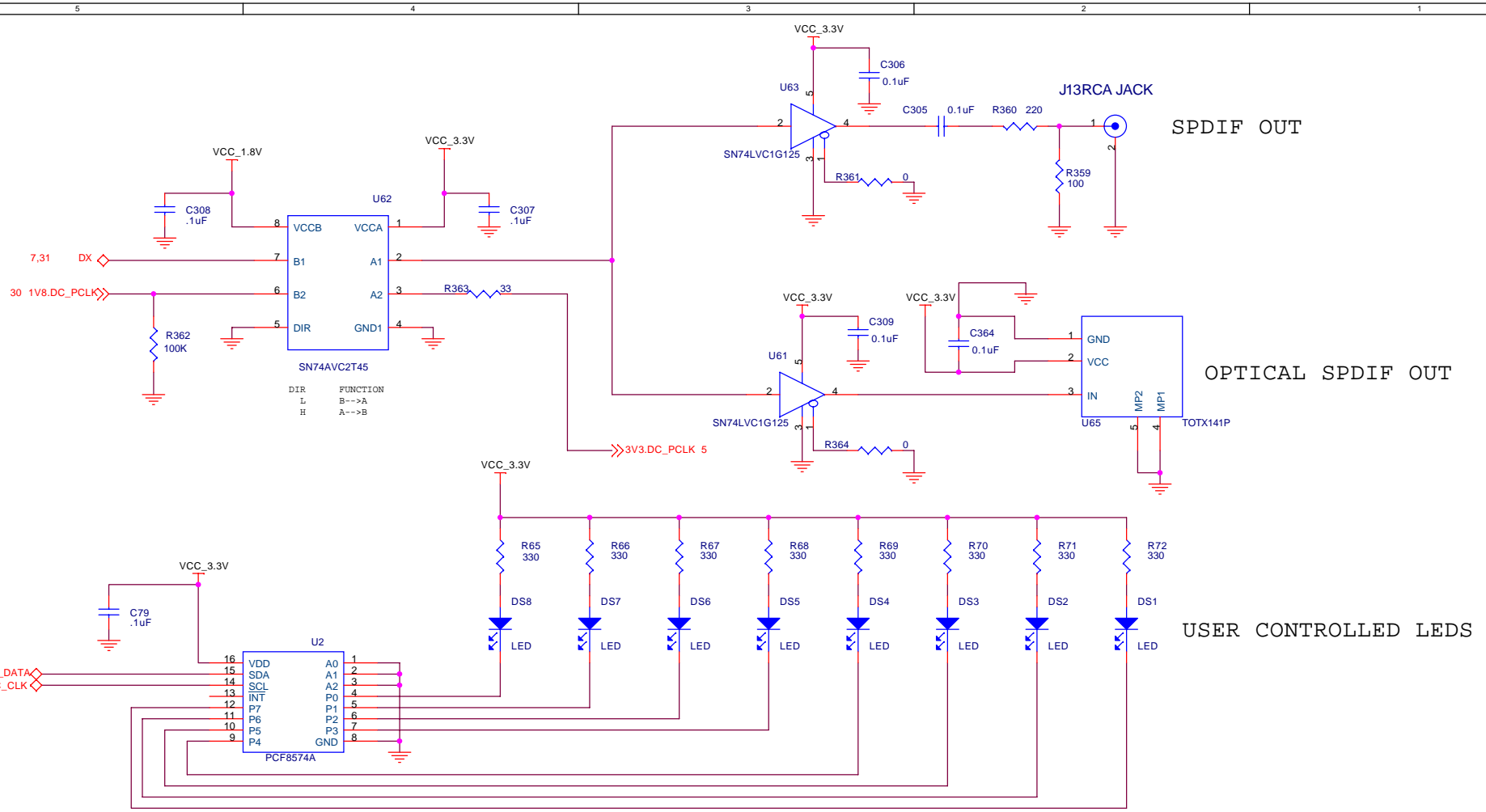

SPECTRUM DIGITAL INCORPORATED			
Title: DAVINCI EVALUATION MODULE			
Page Contents: SPDIF OUTPUTS & USER LEDS			
Size: B	DWG NO: 508162-0001	Revision: A	
Date: Wednesday, April 19, 2006		Sheet 27 of 35	

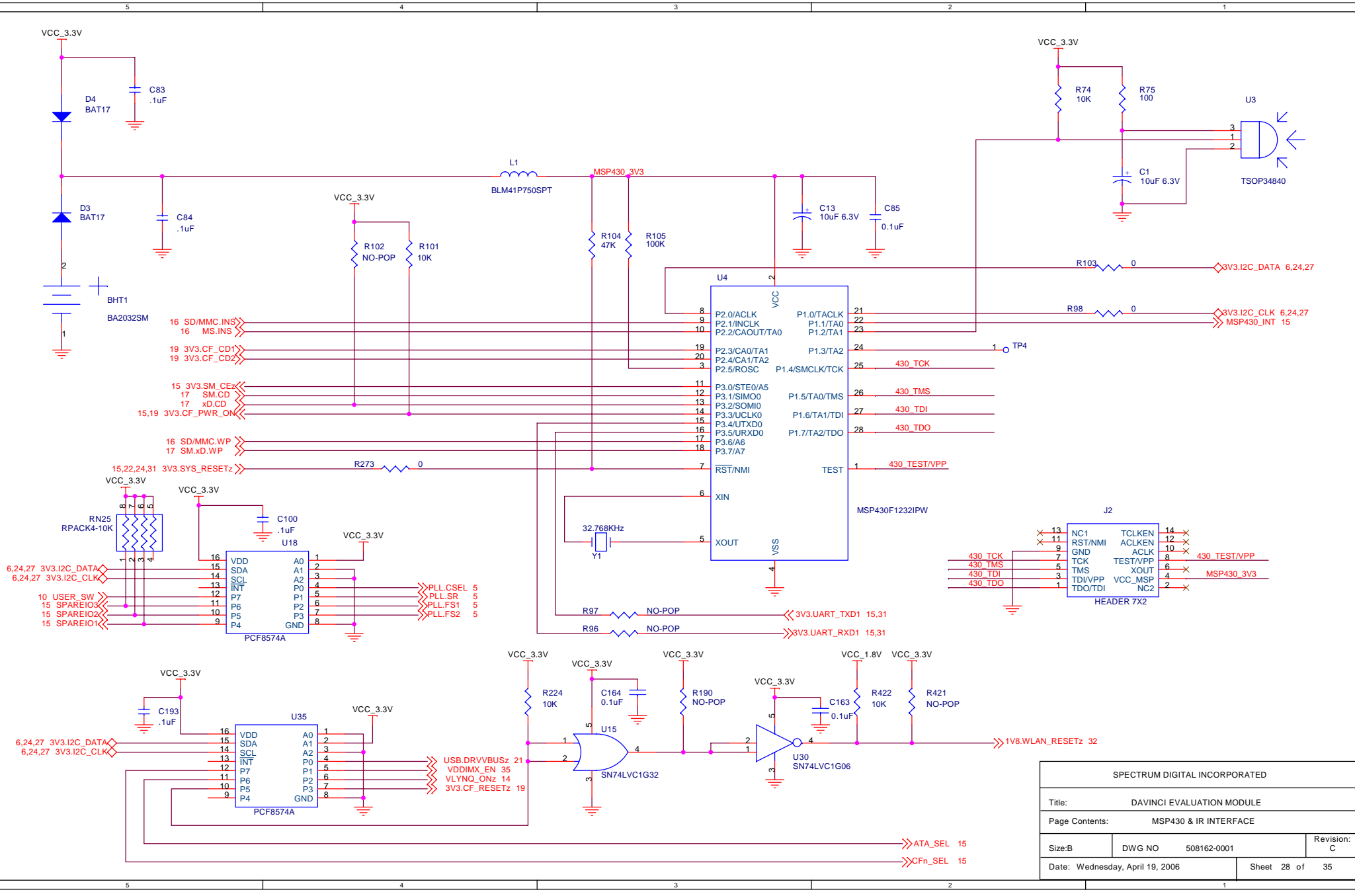

SPECTRUM DIGITAL INCORPORATED			
Title: DAVINCI EVALUATION MODULE			
Page Contents: MSP430 & IR INTERFACE			
Size: B	DWG NO: 508162-0001	Revision: C	
Date: Wednesday, April 19, 2006		Sheet 28 of 35	

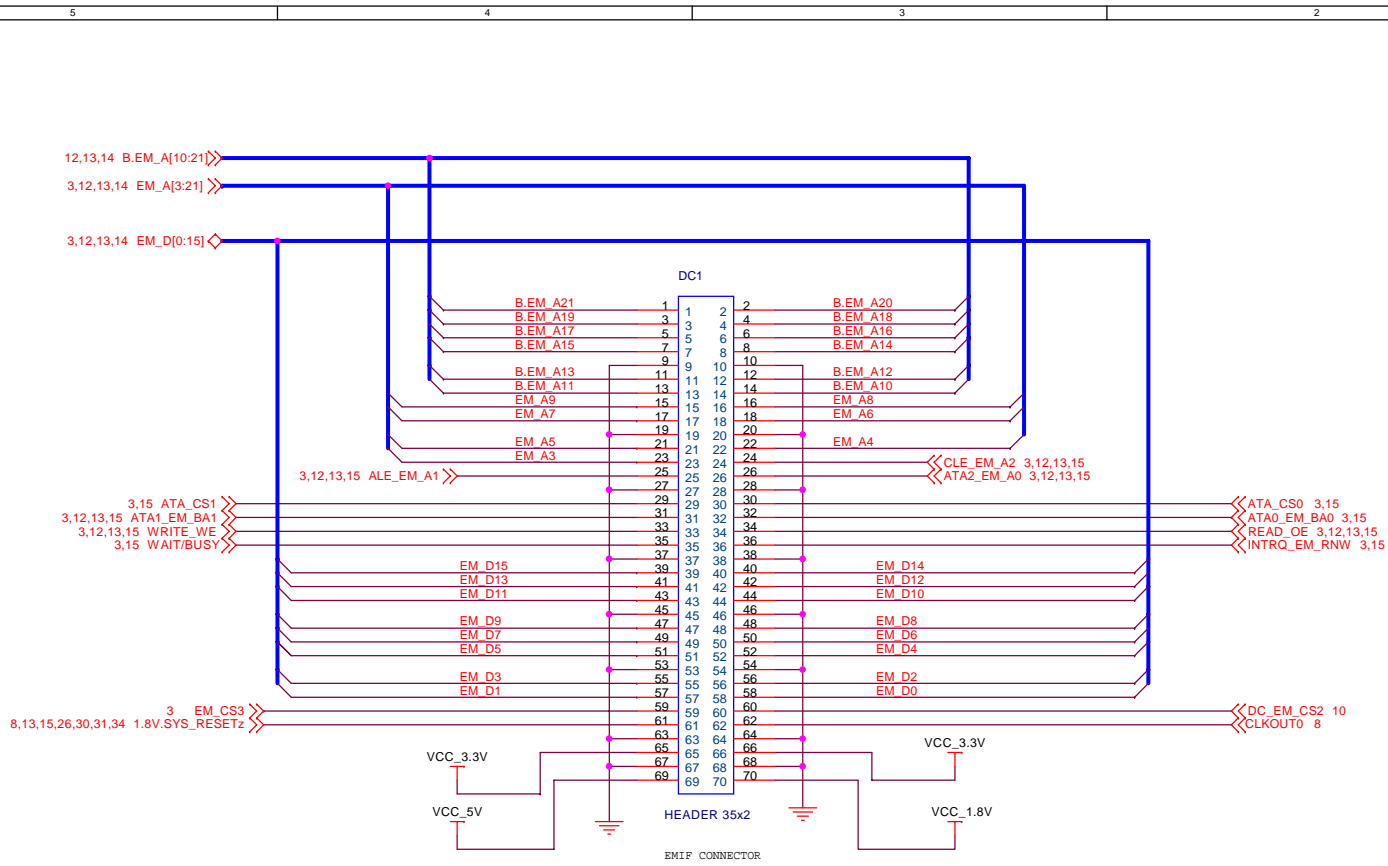

SPECTRUM DIGITAL INCORPORATED			
Title: DAVINCI EVALUATION MODULE			
Page Contents: EMIF EXPANSION CONNECTOR			
Size: B	DWG NO: 508162-0001	Revision: A	
Date: Wednesday, April 19, 2006		Sheet 29 of 35	

VIDEO INPUT CONNECTOR

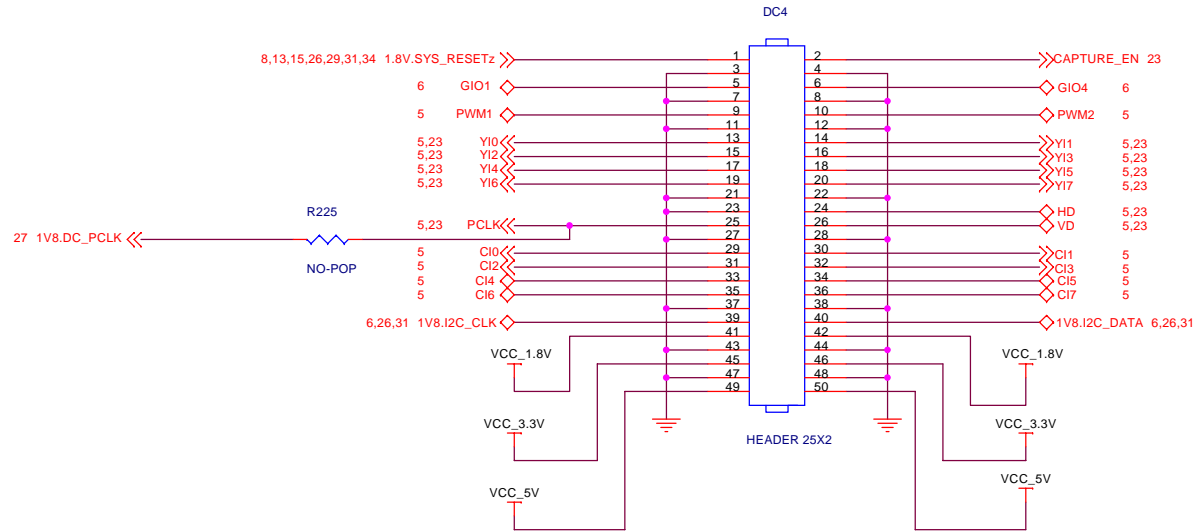

VIDEO OUTPUT CONNECTOR

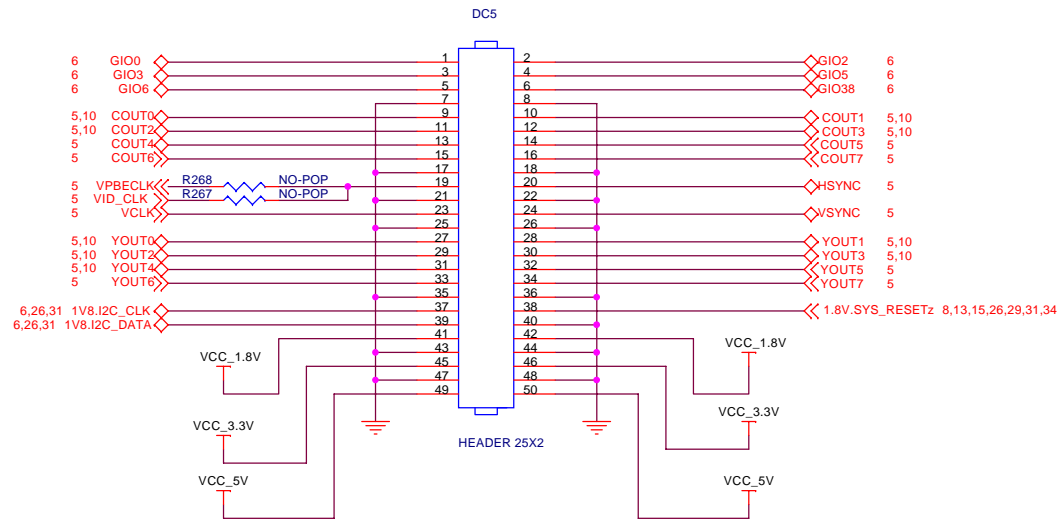

SPECTRUM DIGITAL INCORPORATED			
Title: DAVINCI EVALUATION MODULE			
Page Contents: VIDEO INPUT/OUTPUT CONNECTORS			
Size: B	DWG NO	508162-0001	Revision: A
Date: Wednesday, April 19, 2006			Sheet 30 of 35

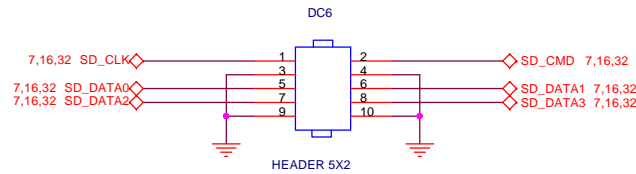
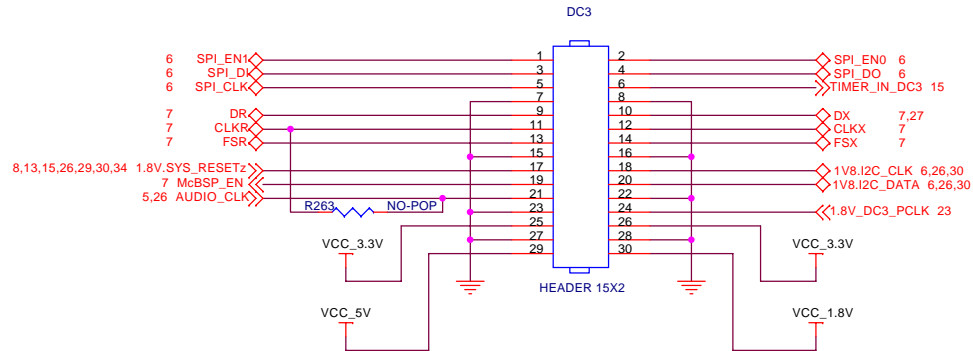
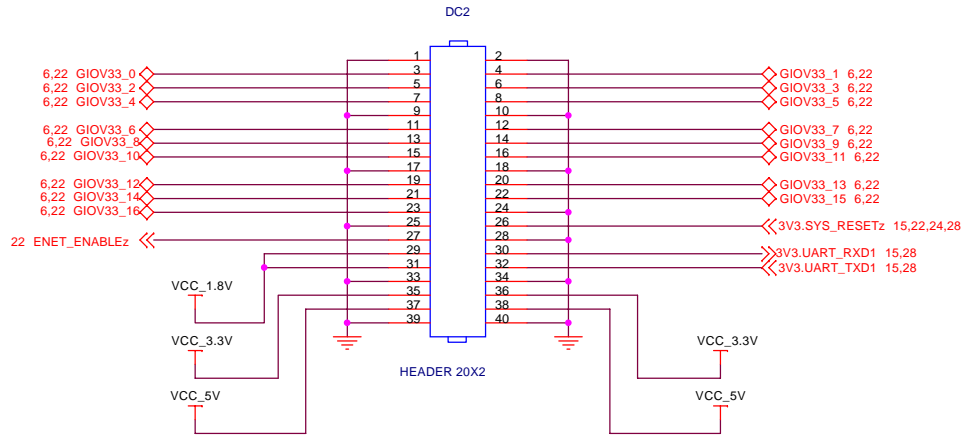

SPECTRUM DIGITAL INCORPORATED			
Title: DAVINCI EVALUATION MODULE			
Page Contents: EMAC/GIO & McBSP/SPI & SD CONNECTORS			
Size: B	DWG NO	508162-0001	Revision: A
Date: Wednesday, April 19, 2006		Sheet 31 of 35	

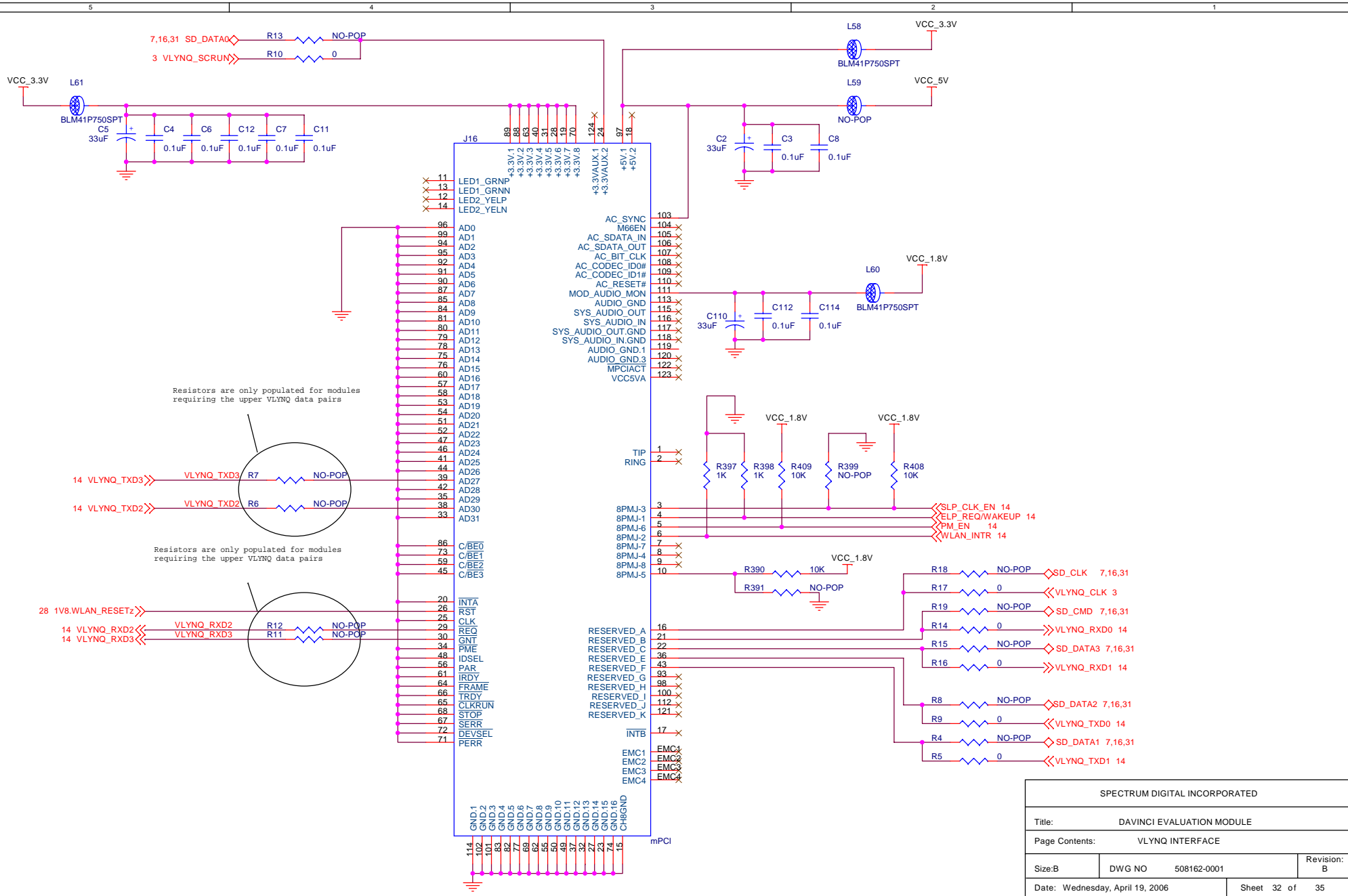

Resistors are only populated for modules requiring the upper VLYNQ data pairs

Resistors are only populated for modules requiring the upper VLYNQ data pairs

SPECTRUM DIGITAL INCORPORATED			
Title: DAVINCI EVALUATION MODULE			
Page Contents: VLYNQ INTERFACE			
Size: B	DWG NO	508162-0001	Revision: B
Date: Wednesday, April 19, 2006		Sheet 32 of 35	

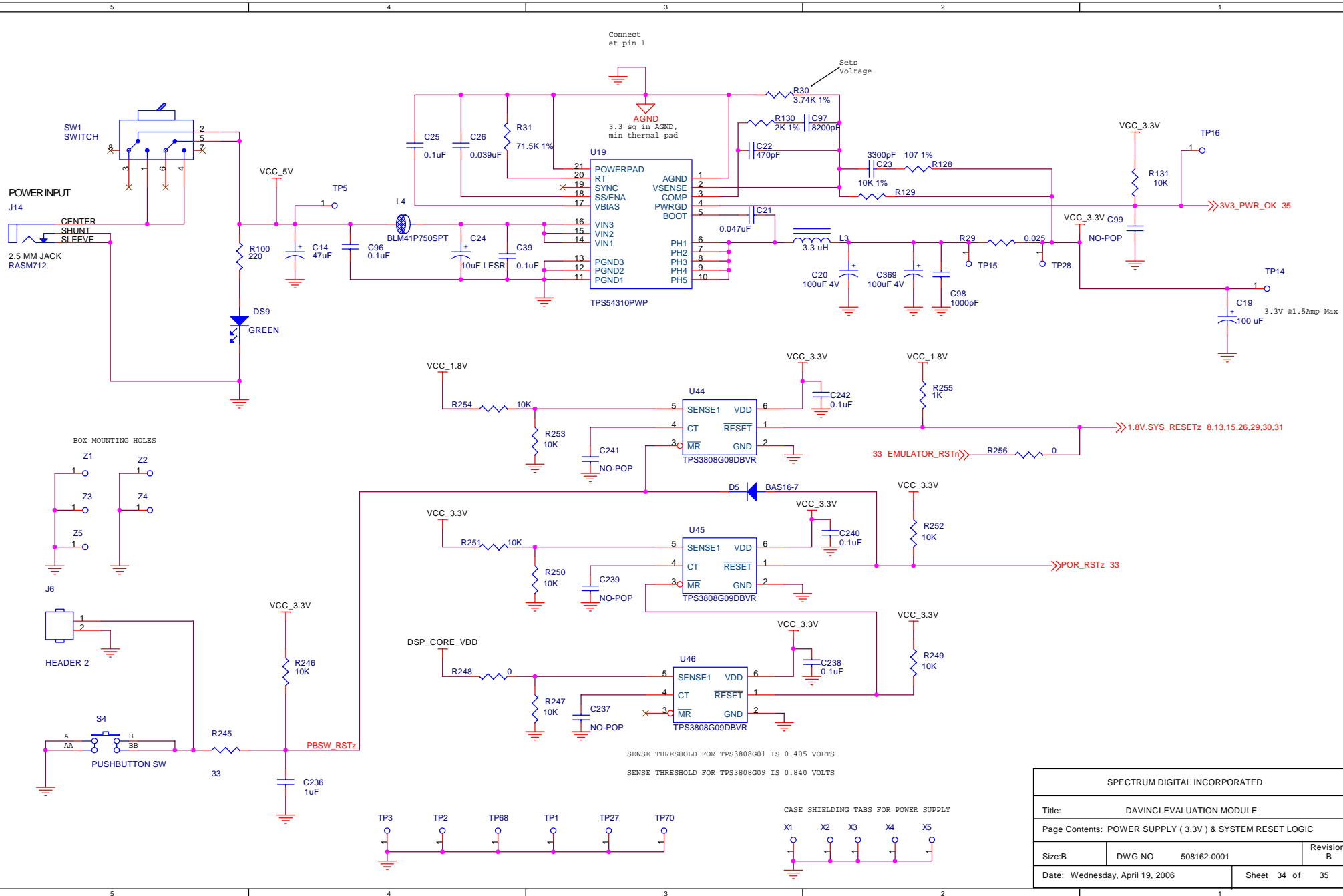

SPECTRUM DIGITAL INCORPORATED			
Title: DAVINCI EVALUATION MODULE			
Page Contents: POWER SUPPLY (3.3V) & SYSTEM RESET LOGIC			
Size: B	DWG NO	508162-0001	Revision: B
Date: Wednesday, April 19, 2006		Sheet 34 of 35	

