

REV	DESCRIPTION	DATE	APPROVED
A	Initial schematic ready for layout - Alpha Release	09/15/05	RRP
B	Beta Release	10/15/05	RRP

NOTES, UNLESS OTHERWISE SPECIFIED:

1. RESISTANCE VALUES IN OHMS.
2. CAPACITANCE VALUES IN MICROFARADS.
3. REFERENCE DESIGNATORS USED:
4. ALL 0.1 uF AND 0.01uF CAPACITORS ARE DECOUPLING CAPS UNLESS OTHERWISE NOTED. THEY ARE SHOWN ON THE PAGE WITH THE INTEGRATED CIRCUITS THEY SHOULD BE PLACED NEAR.
5. OBSERVE THE FOLLOWING LAYOUT NOTES:

DDR2 ROUTING PER APPLICATION NOTE  
SRIO ROUTING PER APPLICATION NOTE

6. BOARD PROPERTIES

- A. ROUTE TO WITHIN 10% OF MANHATTAN DISTANCE
- B. General layers 50 +/- 5 OHM MATCHED IMPEDANCE
- C. OUTER LAYERS 0.5 OZ CU /W 0.5 OZ AU PLATING
- D. INNER LAYERS 1.0 OZ CU
- E. FR4 BOARD MATERIAL
- F. MINIMUM TRACE WIDTH/SPACING 4 MILS
- G. MINIMUM VIA SIZE 10/19 MIL
- H. LAYER STACKUP:

SCHMATIC CONTENTS:

- 1 COVER SHEET
- 2 USER OPTIONS
- 3 Clock Inputs
- 4 645X DDR2 Interface
- 5 DDR2 Memories
- 6 645X EMIF A
- 7 BOOT Options
- 8 CPLD
- 9 FLASH MEMORY
- 10 645X MII INTERFACE
  
- 11 MCBSP INTERFACE
- 12 645X HOST PORT INTERFACE
- 13 645X SRIO INTERFACE
- 14 DSK DAUGHTERCARD BUFFERS
- 15 DSK DAUGHTERCARD INTERFACE
- 16 645X POWER PINS I
- 17 645X POWER PINS II
- 18 645X EMULATION
- 19 645X EMULATION INTERFACE
  
- 20 EMULATION INTERFACE
- 21 HIERARCHICAL BLOCKS
- 22 645X RGMII INTERFACE
- 23 645X DECOUPLING CAPS I
- 24 645X DECOUPLING CAPS II
- 25 POWER INPUT
- 26 AIC23 CODEC
- 27 ETHERNET PHY
- 28 DSK POWER SUPPLIES I
- 29 DSK POWER SUPPLIES II

REVISION STATUS OF SHEETS

REV	DATE	BY	DESCRIPTION	DATE	BY	DESCRIPTION	DATE	BY	DESCRIPTION	DATE	BY	DESCRIPTION
REV	A	A	A	A	A	A	A	A	A	A	A	
SH	21	22	23	24	25	26	27	28	29			
REV	A	A	A	A	A	A	A	A	A	A	A	
SH	11	12	13	14	15	16	17	18	19	20		
REV	A	A	A	A	A	A	A	A	A	A	A	
SH	1	2	3	4	5	6	7	8	9	10		

DWN	R.R.P.	SEPT 15,2005
CHK	R.R.P.	SEPT 15,2005
ENGR	J.T.C.	SEPT 15,2005
ENGR-MGR	R.R.P.	SEPT 15,2005
QA	C.M.D.	SEPT 15,2005
MFG	C.M.D.	SEPT 15,2005
RLSE	T.M.K.	SEPT 15,2005

SPECTRUM DIGITAL INCORPORATED			
Title:	TMS320C6455 DSK		
Page Contents:	Title Block		
Size: B	DWG NO	508552-0001	Revision: B
Date:	Monday, March 06, 2006	Sheet 1 of	34

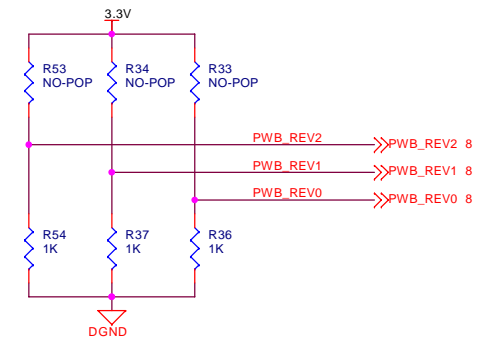
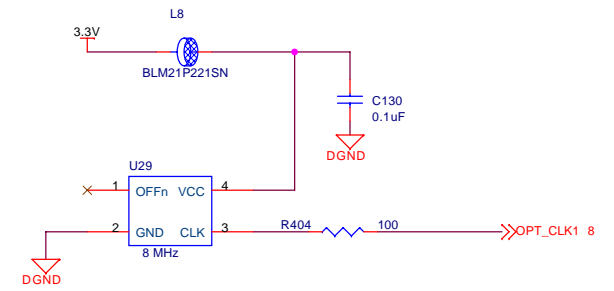
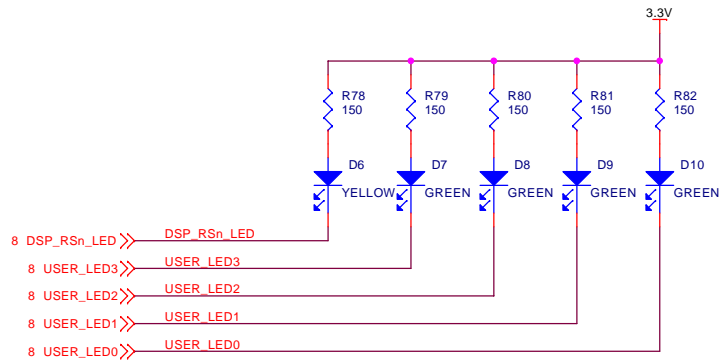
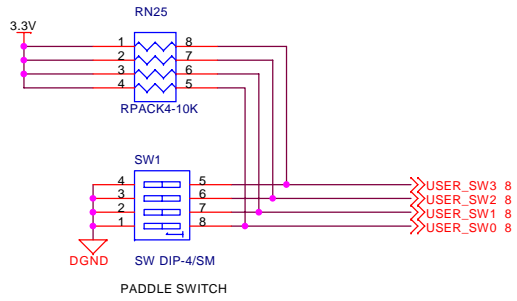

SPECTRUM DIGITAL INCORPORATED			
Title: TMS320C6455 DSK			
Page Contents: Title Block			
Size: B	DWG NO	508552-0001	Revision: A
Date: Wednesday, January 25, 2006		Sheet 2 of 34	

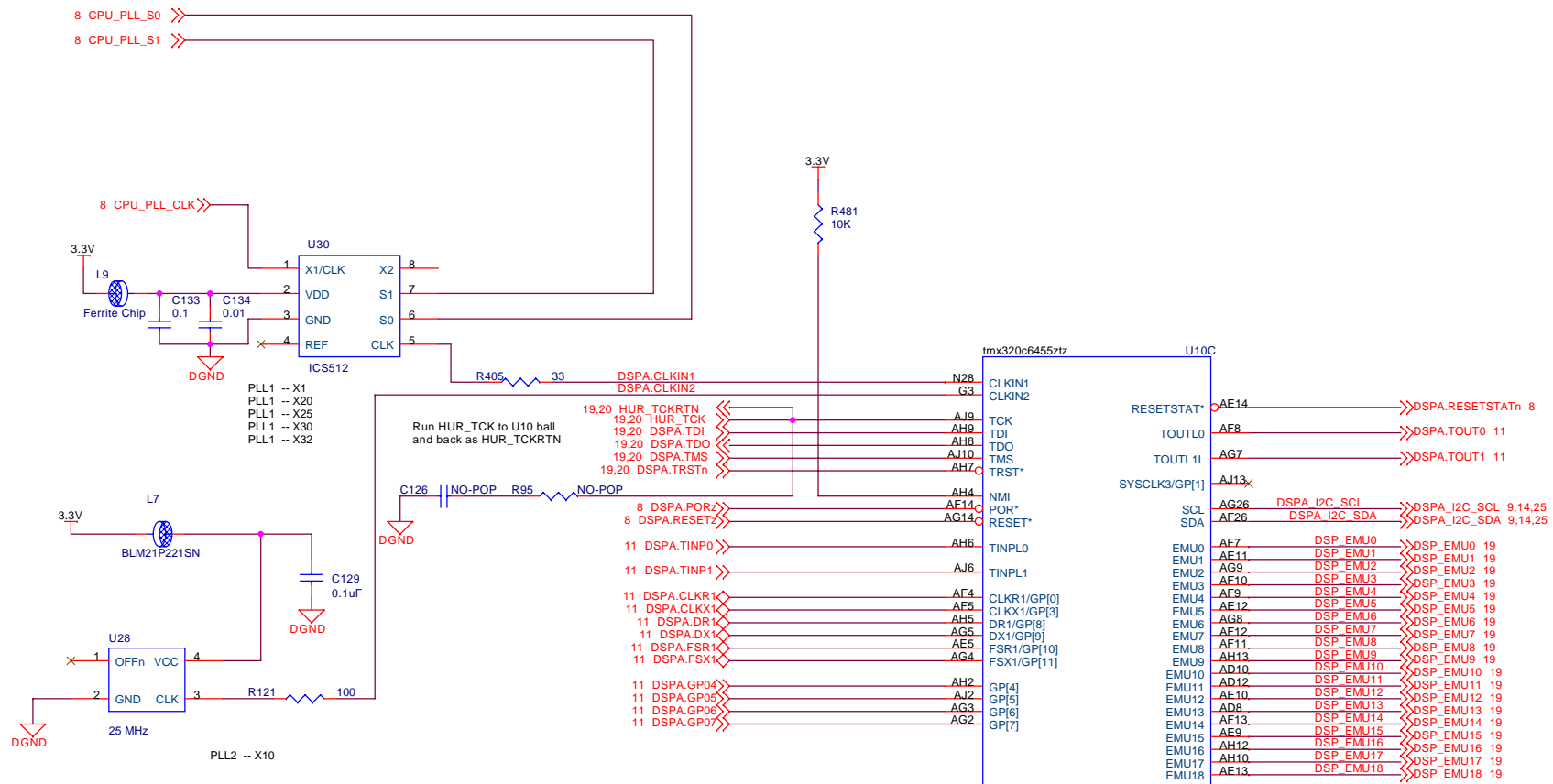

S1	S0	MULTIPLY	OUTPUT
0	0	4X	100 MHz
0	OPEN	5.33X	133.25 MHz
0	1	5X	125 MHz
OPEN	0	2.5X	62.5 MHz
OPEN	OPEN	2X	50 MHz
OPEN	1	3.33X	83.25 MHz
1	0	6X	150 MHz
1	OPEN	3X	75 MHz
1	1	8X	200 MHz

SPECTRUM DIGITAL INCORPORATED		
Title:	TMS320C6455 DSK	
Page Contents:	6455 CLOCK INPUTS	
Size: B	DWG NO 508552-0001	Revision: A
Date: Monday, March 06, 2006	Sheet 3 of 34	

NOTE: Route DUT\_BSDDQGATE0 signals needs to run to DDR memories near D15-D0 and back to DUT\_TBSDDGATE1.

NOTE: Route DUT\_BSDDQGATE2 signals needs to run to DDR memories near D31-D16 and back to DUT\_TBSDDGATE3.

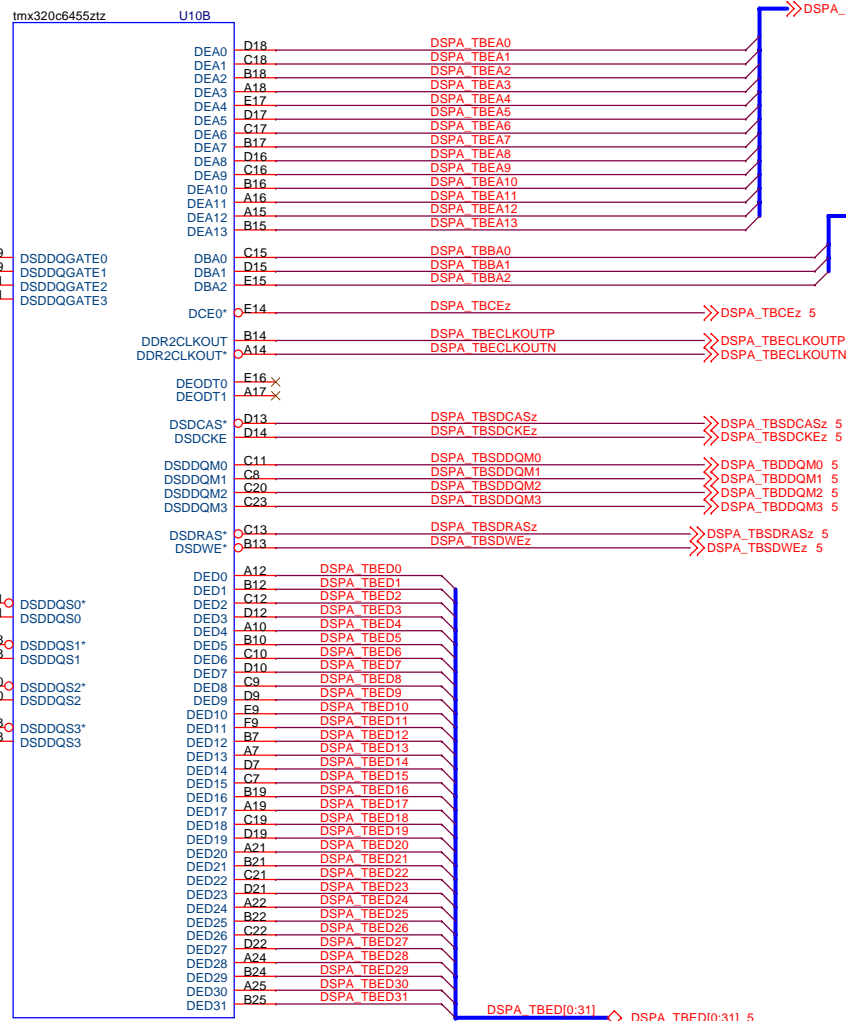
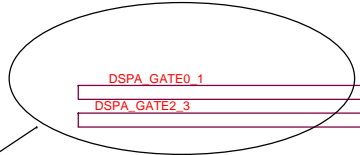

SPECTRUM DIGITAL INCORPORATED			
Title: TMS320C6455 DSK			
Page Contents: 6455 DDR Interface			
Size: B	DWG NO	508552-0001	Revision: A
Date: Wednesday, January 25, 2006	Sheet 4 of		34

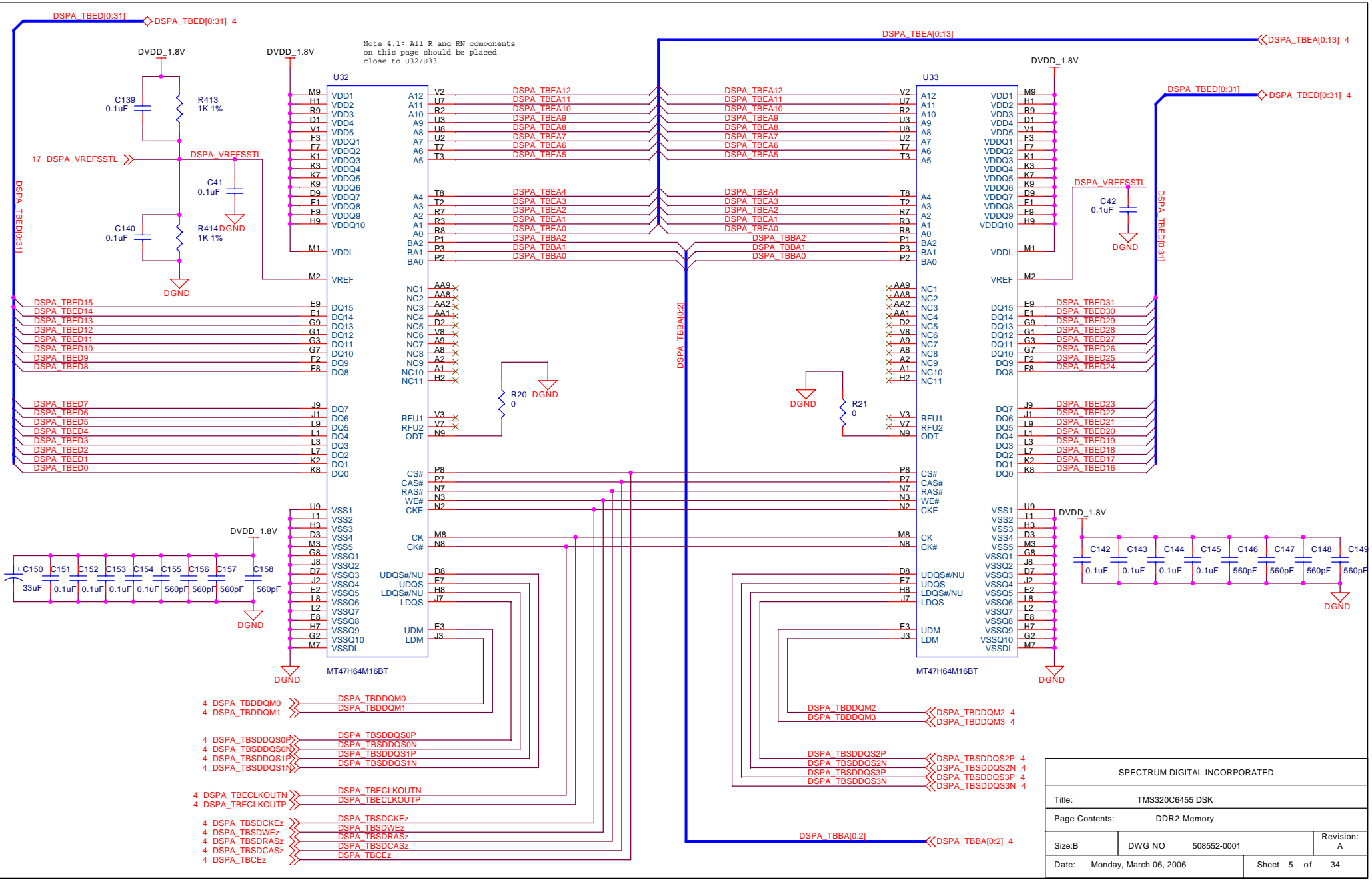

SPECTRUM DIGITAL INCORPORATED			
Title: TMS320C6455 DSK			
Page Contents: DDR2 Memory			
Size: B	DWG NO	508552-0001	Revision: A
Date: Monday, March 06, 2006	Sheet 5 of		34

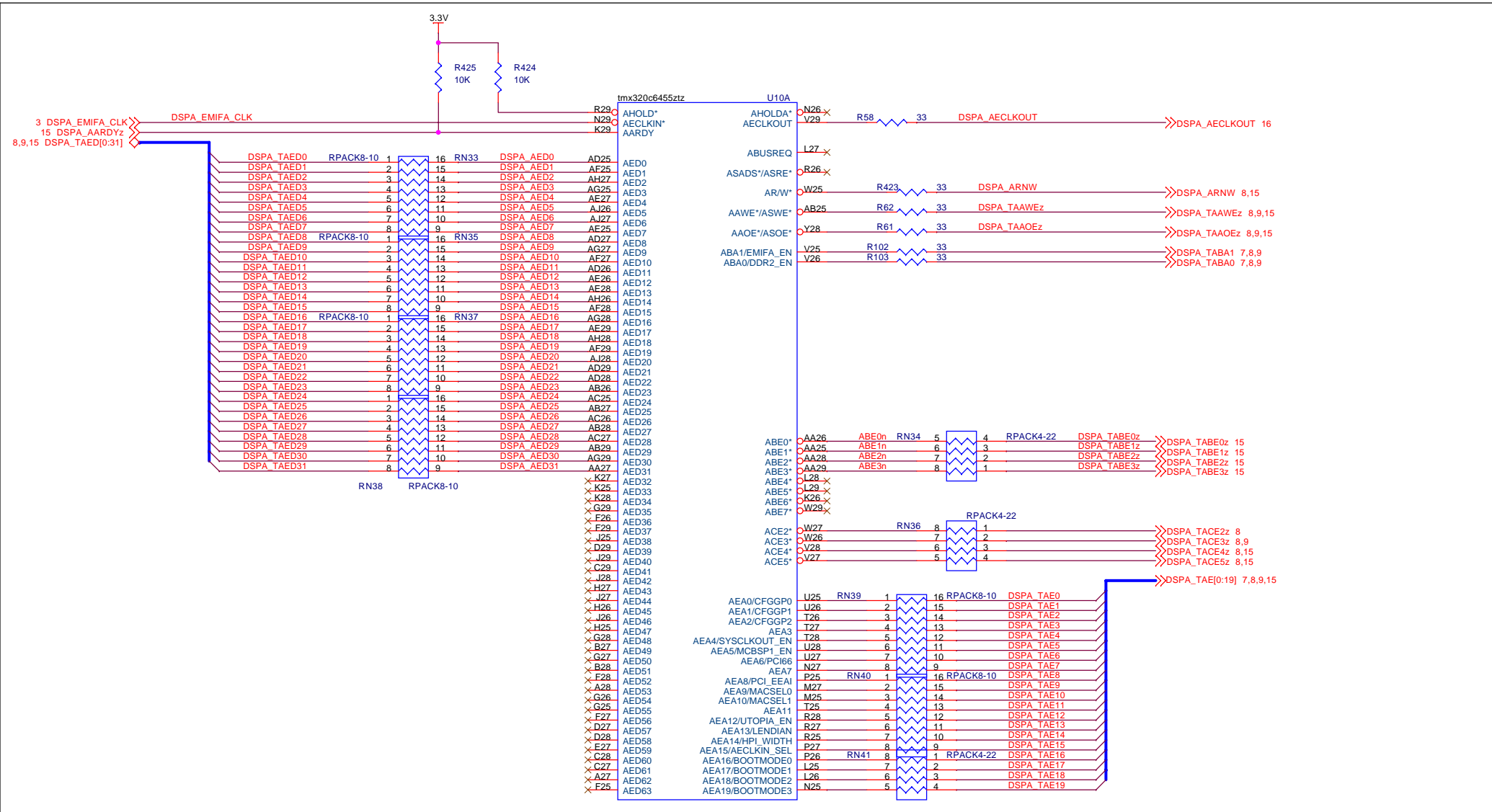

SPECTRUM DIGITAL INCORPORATED			
Title:		TMS320C6455 DSK	
Page Contents:		6455 Emif A Interface	
Size: B	DWG NO	508552-0001	Revision: A
Date:	Wednesday, January 25, 2006	Sheet 6	of 34

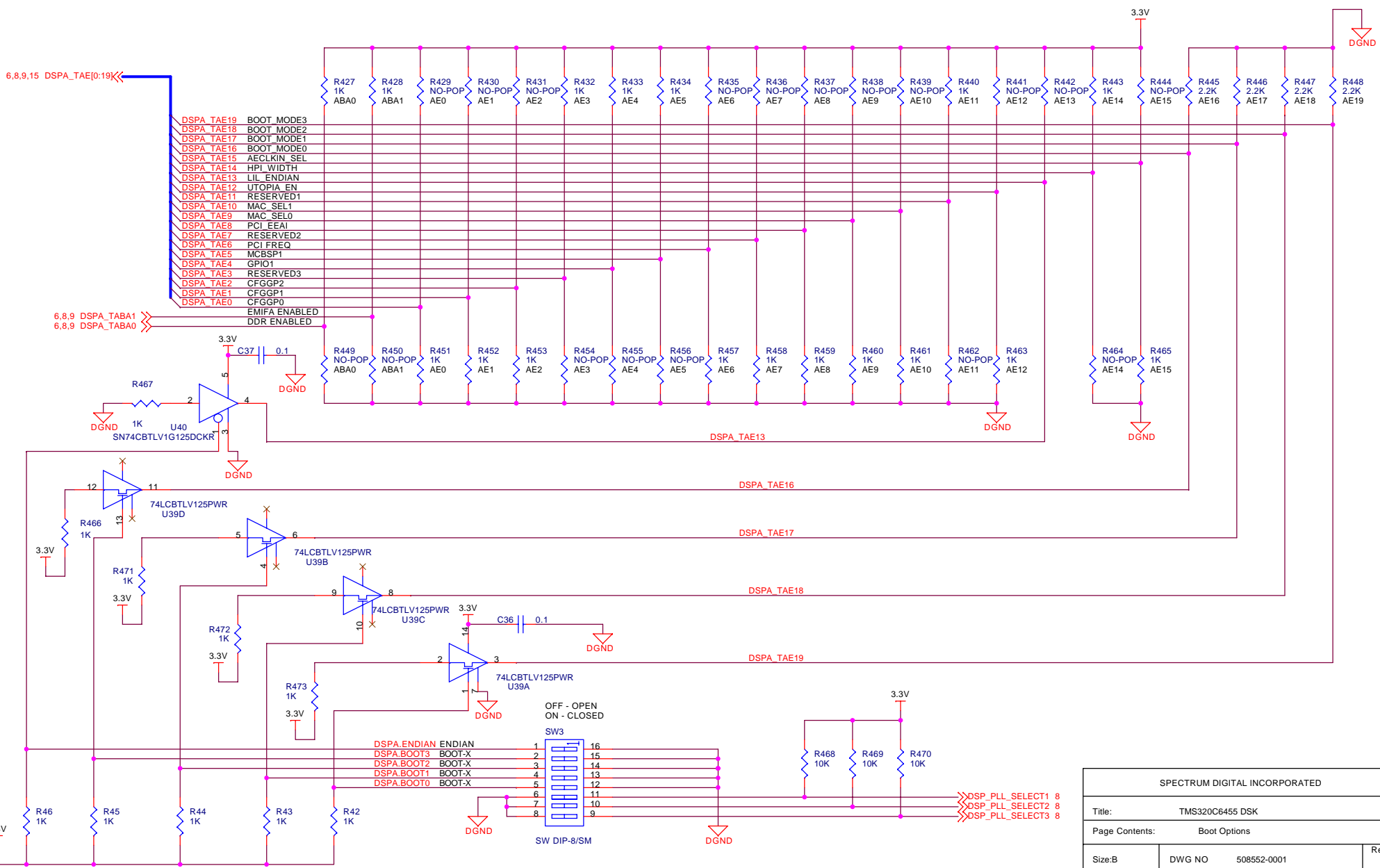

SPECTRUM DIGITAL INCORPORATED		
Title: TMS320C6455 DSK		
Page Contents: Boot Options		
Size: B	DWG NO 508552-0001	Revision: B
Date: Wednesday, January 25, 2006	Sheet 7 of 34	

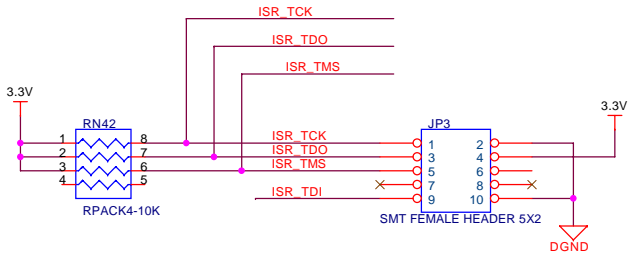
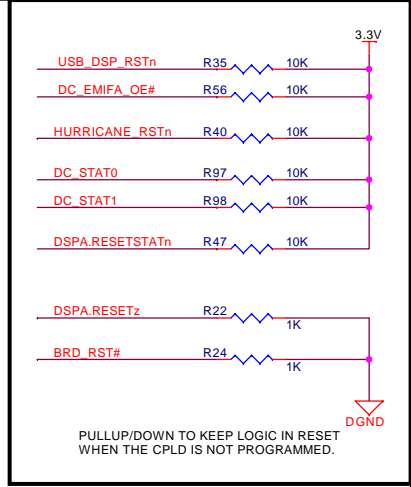
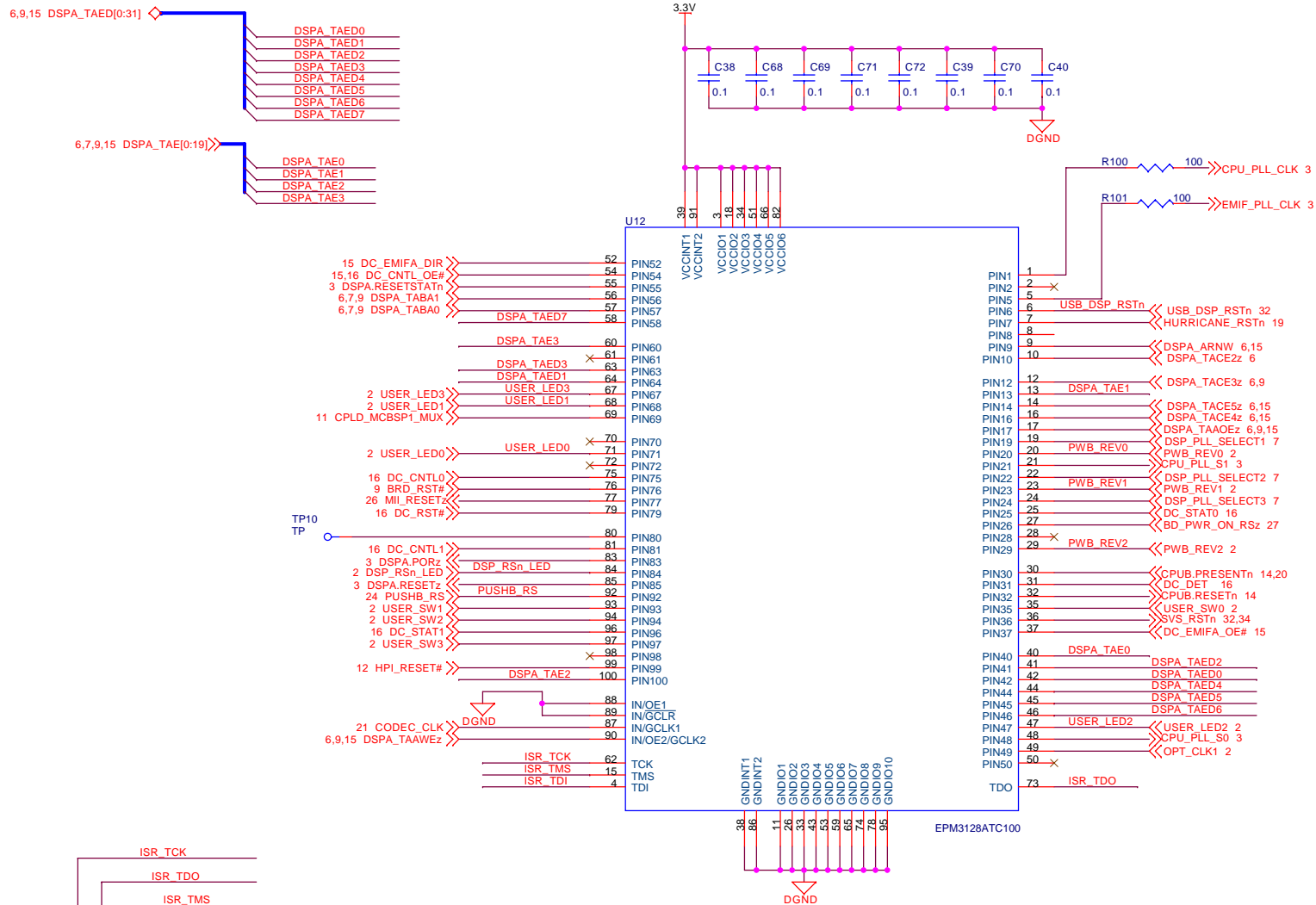

SPECTRUM DIGITAL INCORPORATED			
Title: TMS320C6455 DSK			
Page Contents: CPLD INTERFACE			
Size: B	DWG NO	508552-0001	Revision: B
Date: Wednesday, January 25, 2006	Sheet 8 of 34		



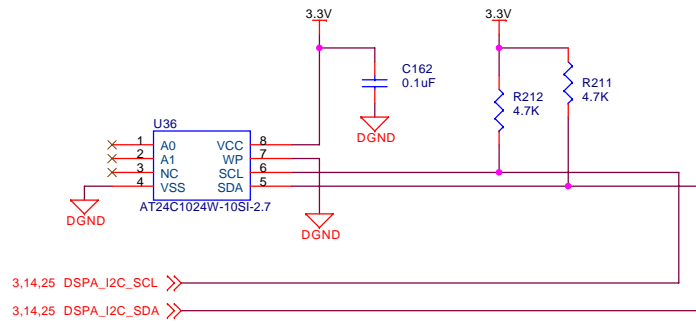
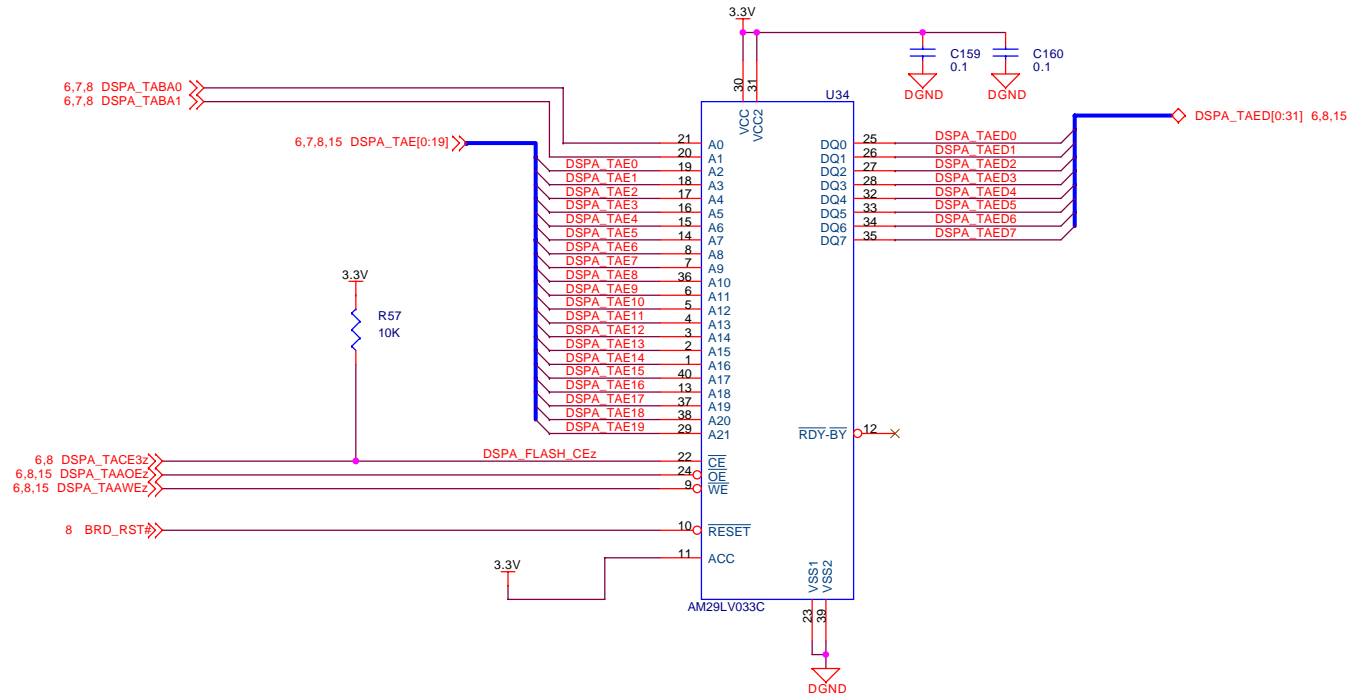

SPECTRUM DIGITAL INCORPORATED			
Title:		TMS320C6455 DSK	
Page Contents:		Flash	
Size: B	DWG NO	508552-0001	Revision: A
Date:	Wednesday, January 25, 2006	Sheet 9	of 34

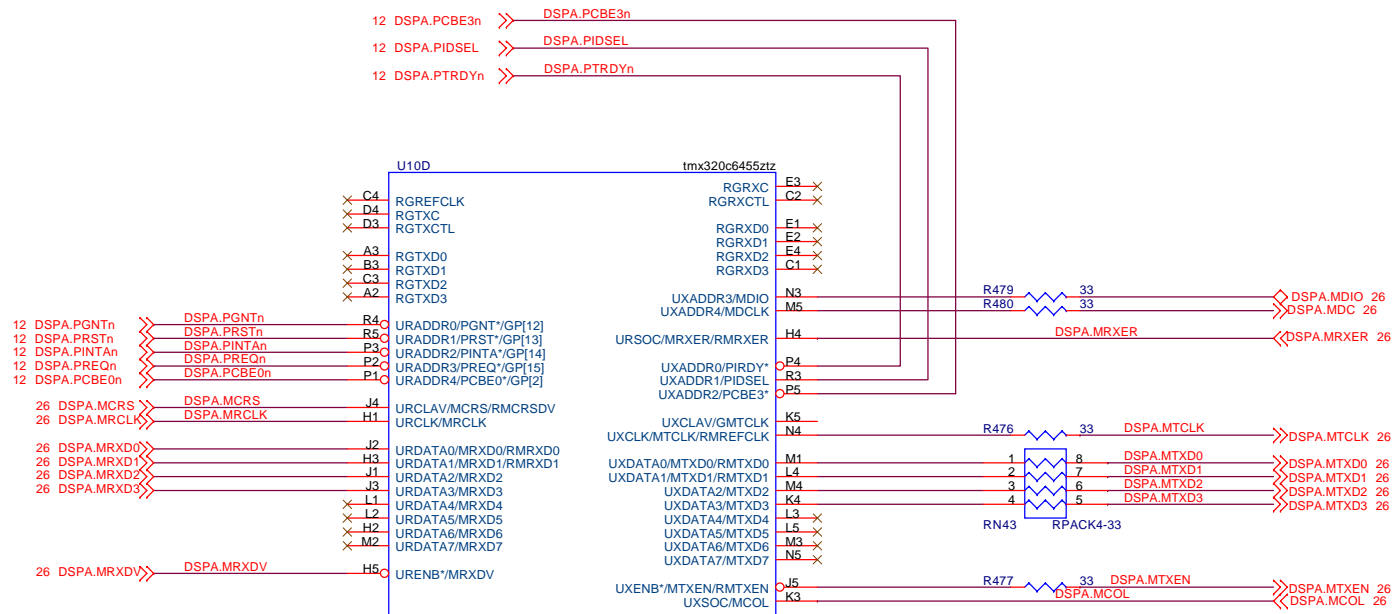

SPECTRUM DIGITAL INCORPORATED			
Title: TMS320C6455 DSK			
Page Contents: UTOPIA INTERFACE			
Size: B	DWG NO	508552-0001	Revision: A
Date: Wednesday, January 25, 2006	Sheet 10 of 34		

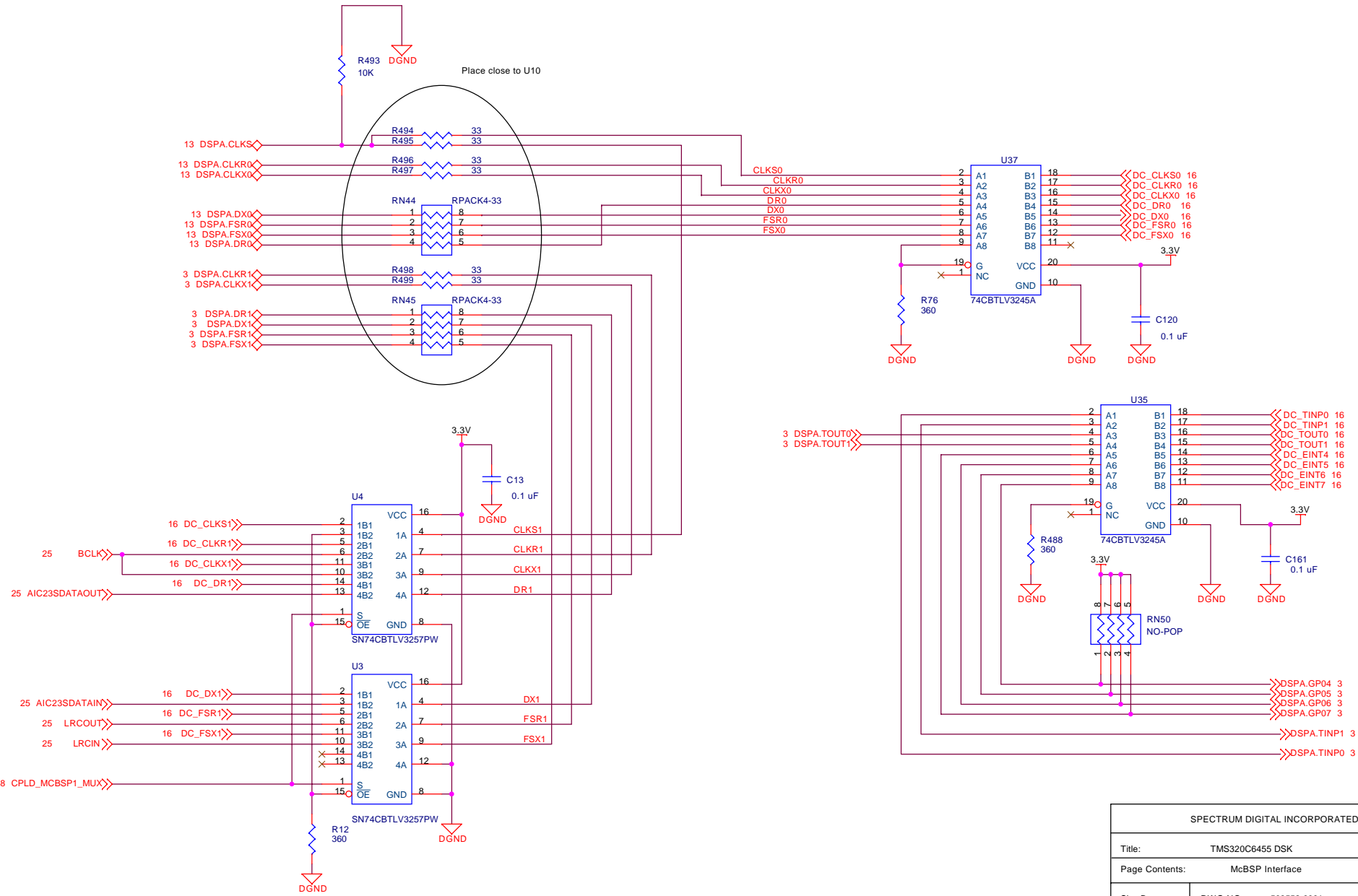

SPECTRUM DIGITAL INCORPORATED			
Title: TMS320C6455 DSK			
Page Contents: McBSP Interface			
Size: B	DWG NO	508552-0001	Revision: B
Date: Wednesday, January 25, 2006	Sheet 11 of 34		

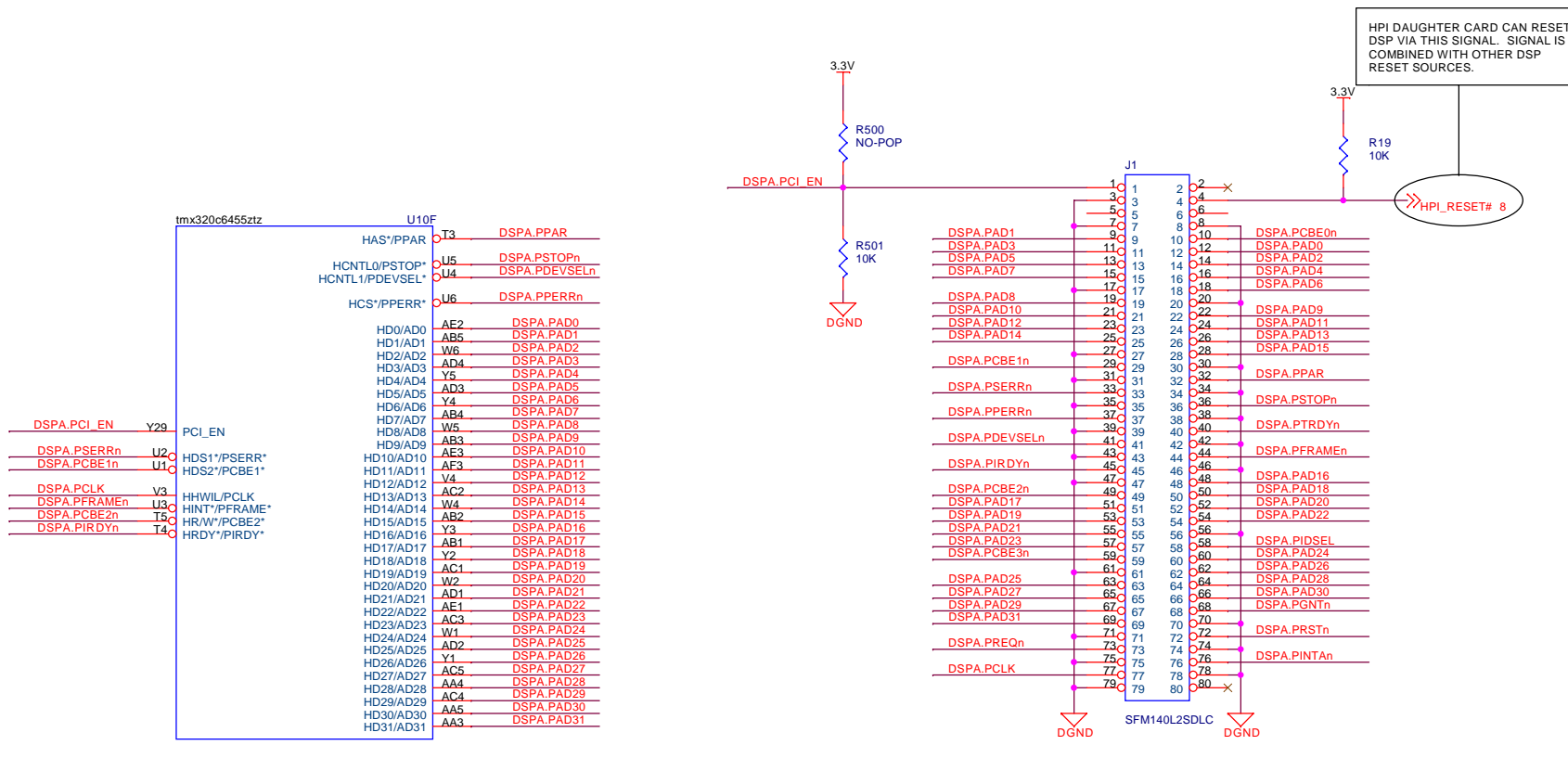

HPI DAUGHTER CARD CAN RESET DSP VIA THIS SIGNAL. SIGNAL IS COMBINED WITH OTHER DSP RESET SOURCES.

HPI\_RESET# 8

- 10 DSPA.PTRDYn >>> DSPA.PTRDYn
- 10 DSPA.PIDSEL >>> DSPA.PIDSEL
- 10 DSPA.PCBE3n >>> DSPA.PCBE3n
- 10 DSPA.PGNTn >>> DSPA.PGNTn
- 10 DSPA.PRSTn >>> DSPA.PRSTn
- 10 DSPA.PINTAn >>> DSPA.PINTAn
- 10 DSPA.PREQn >>> DSPA.PREQn
- 10 DSPA.PCBE0n >>> DSPA.PCBE0n

SPECTRUM DIGITAL INCORPORATED			
Title: TMS320C6455 DSK			
Page Contents: PCI/HOST PORT INTERFACE			
Size: B	DWG NO	508552-0001	Revision: A
Date: Wednesday, January 25, 2006	Sheet 12 of		34

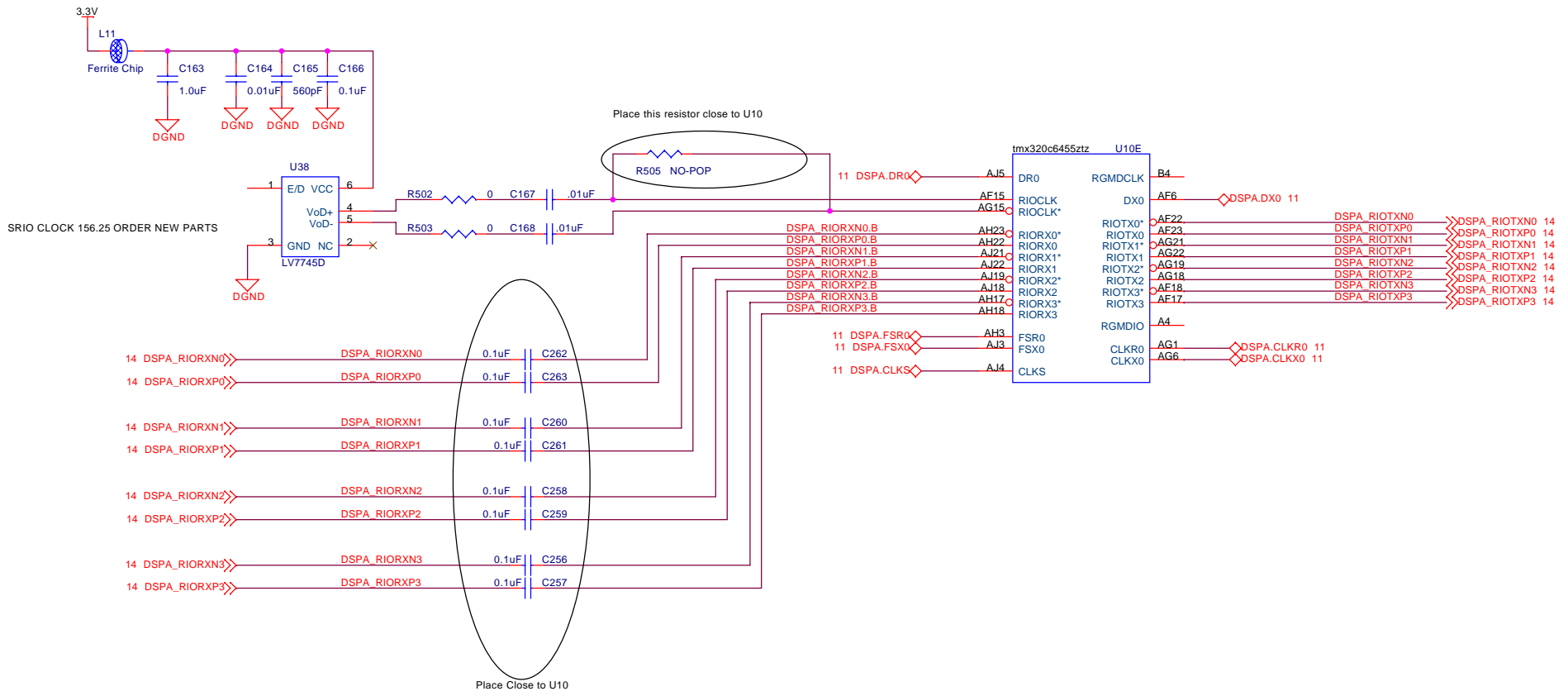

SPECTRUM DIGITAL INCORPORATED			
Title:		TMS320C6455 DSK	
Page Contents:		SRIO INTERFACE	
Size:B	DWG NO	508552-0001	Revision: A
Date: Wednesday, January 25, 2006		Sheet 13 of 34	

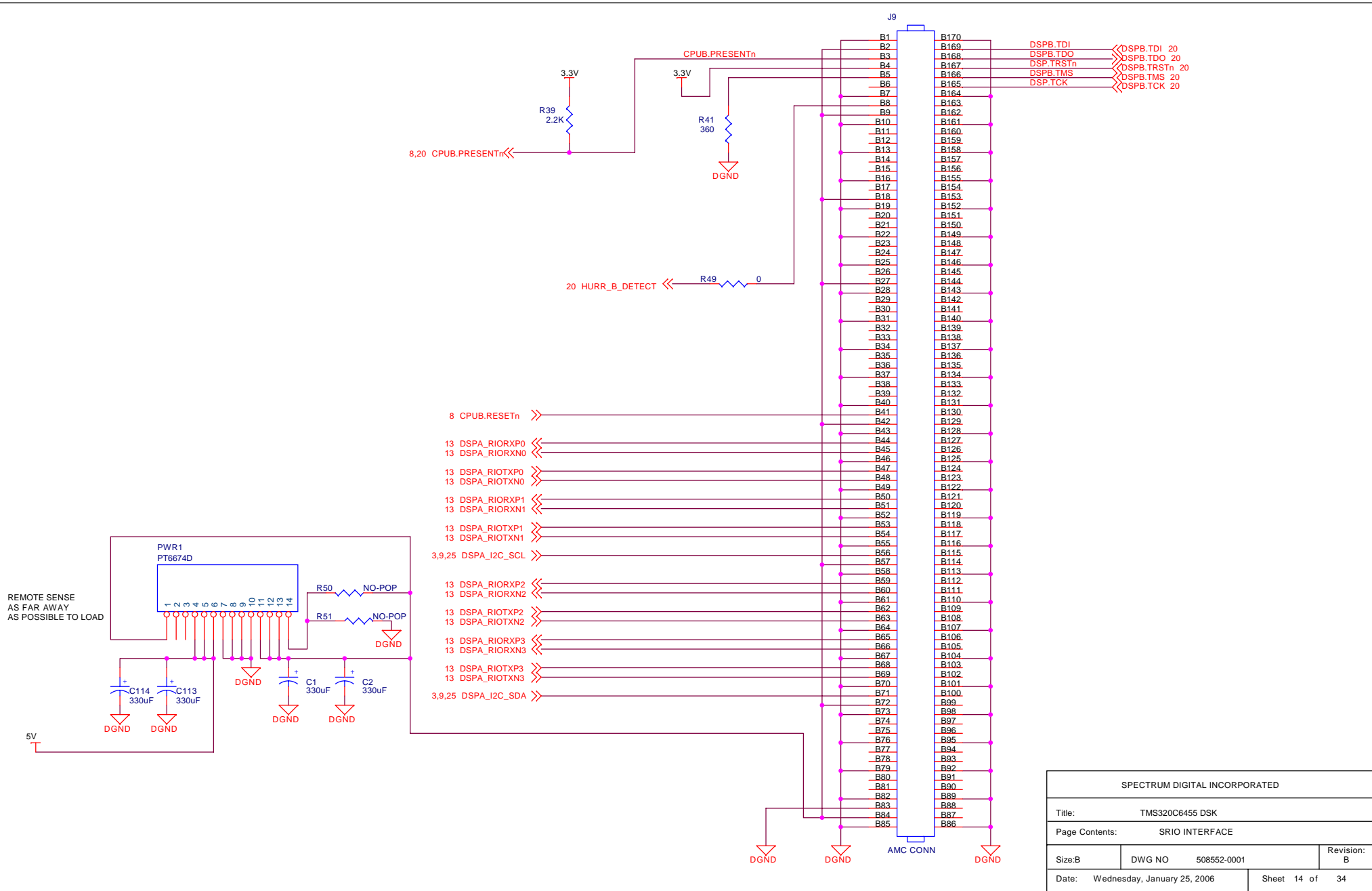

SPECTRUM DIGITAL INCORPORATED		
Title: TMS320C6455 DSK		
Page Contents: SRIO INTERFACE		
Size: B	DWG NO 508552-0001	Revision: B
Date: Wednesday, January 25, 2006	Sheet 14 of	34

6,7,8,9 DSPA\_TAE[0:19]

6,8,9 DSPA\_TAED[0:31]

DC\_D[31..0] 16

DC\_A[21..2] 16

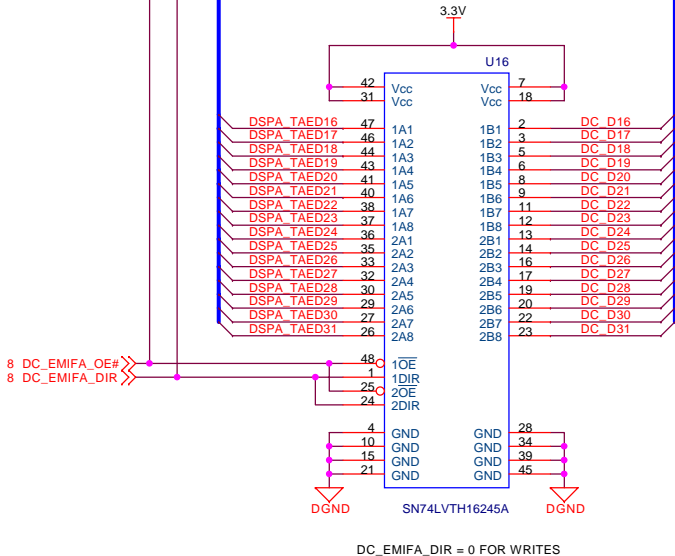
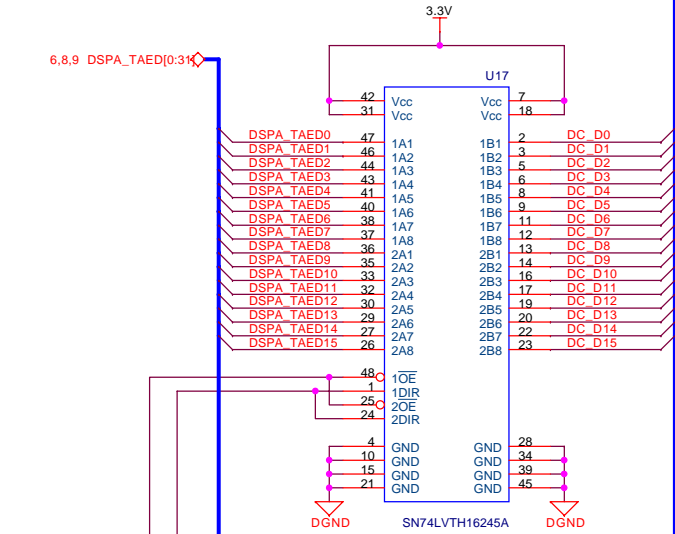

DC\_EMIFA\_DIR = 0 FOR WRITES

8 DC\_EMIFA\_OE#

8 DC\_EMIFA\_DIR

8,16 DC\_CNTL\_OE#

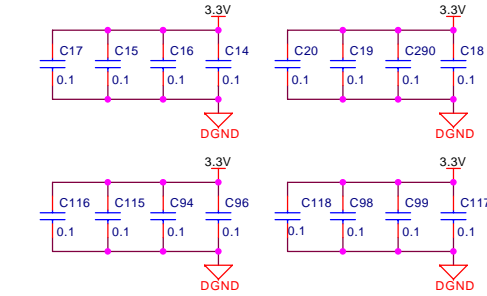
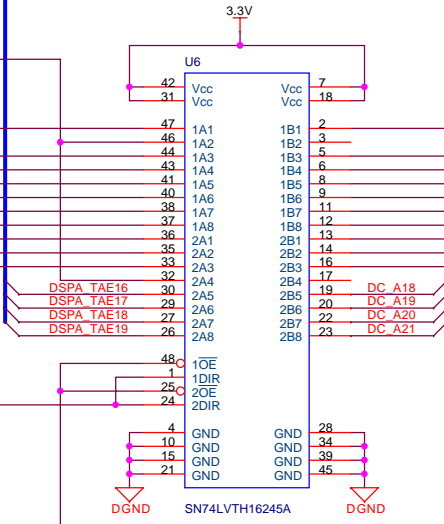
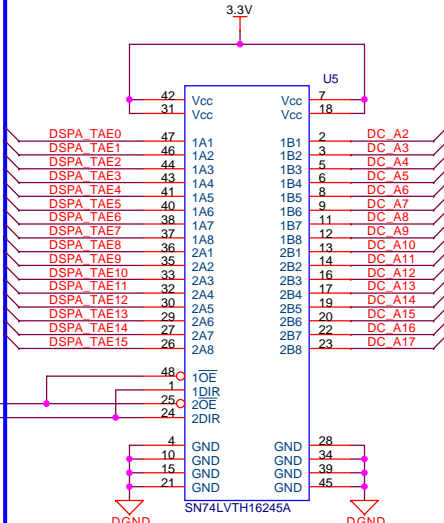
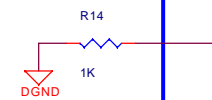

WIRE TAARDY TO DSPA\_AARDYz REV B2

#OE DIR OPERATION  
 L L A <-> B  
 L H A -> B  
 H X ISOLATION

SPECTRUM DIGITAL INCORPORATED		
Title: TMS320C6455 DSK		
Page Contents: DAUGHTERCARD BUFFERING		
Size: B	DWG NO 508552-0001	Revision: A
Date: Wednesday, January 25, 2006	Sheet 15 of 34	

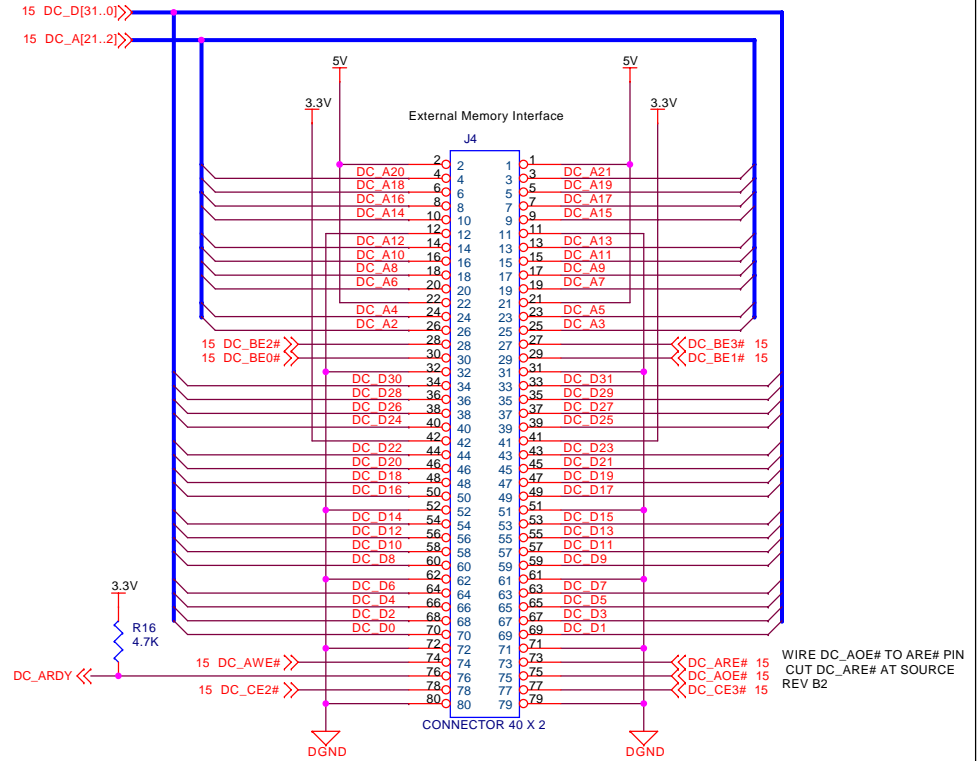
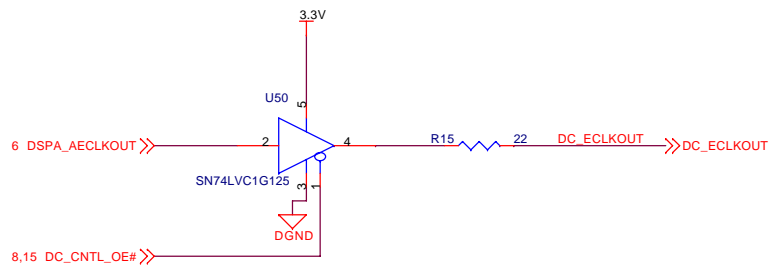
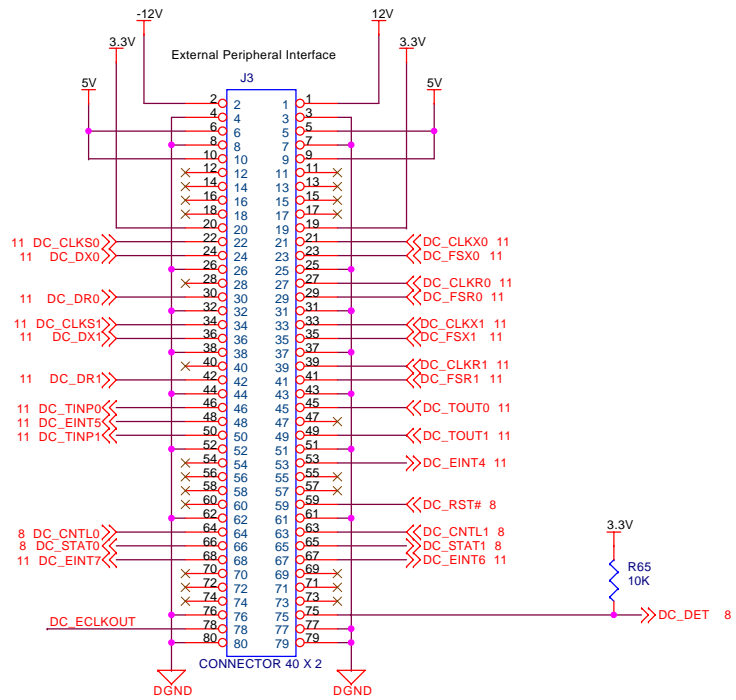

SPECTRUM DIGITAL INCORPORATED			
Title: TMS320C6455 DSK			
Page Contents: DAUGHTERCARD I/F			
Size: B	DWG NO	508552-0001	Revision: A
Date: Wednesday, January 25, 2006	Sheet 16 of		34



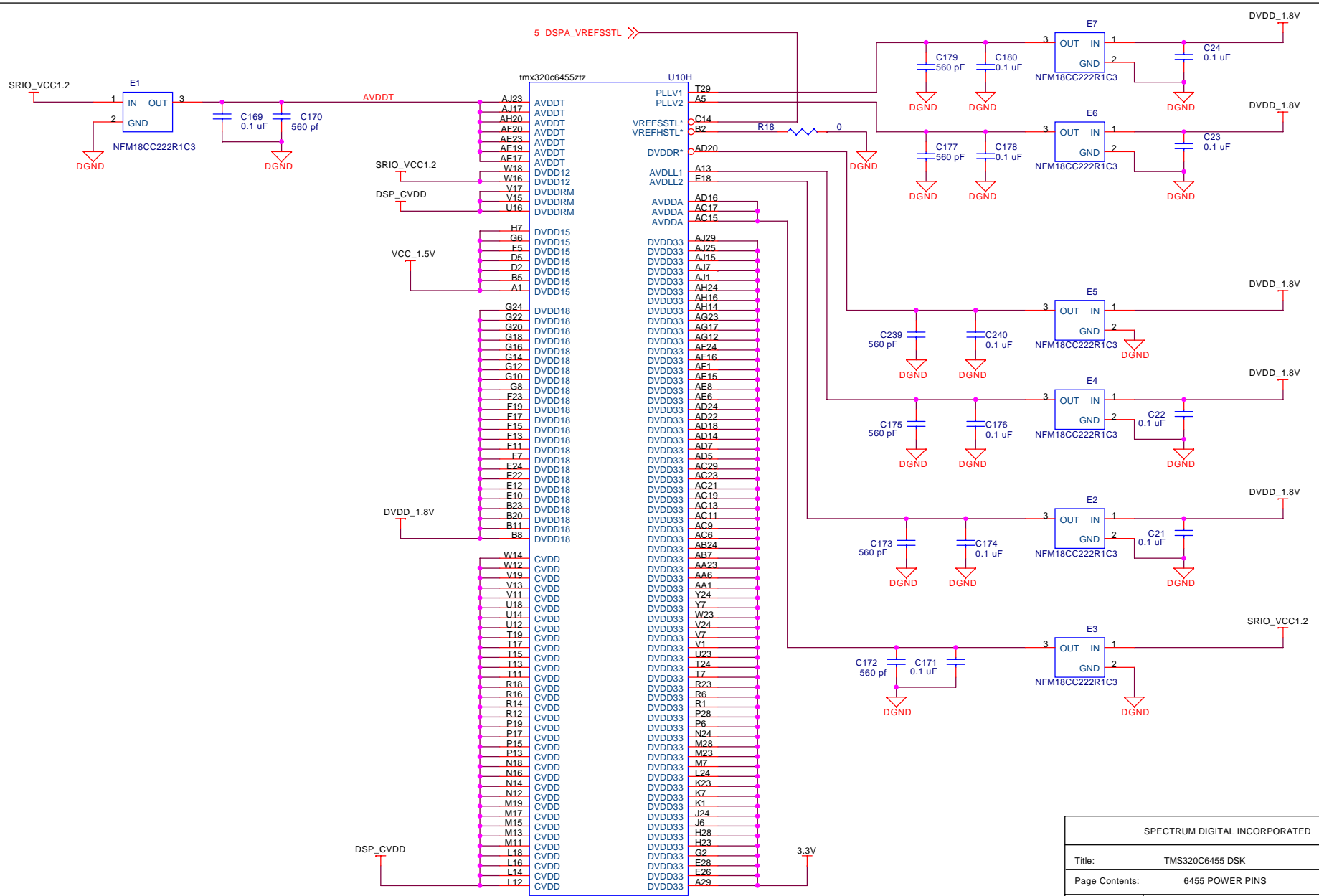

SPECTRUM DIGITAL INCORPORATED			
Title: TMS320C6455 DSK			
Page Contents: 6455 POWER PINS			
Size: B	DWG NO	508552-0001	Revision: A
Date: Wednesday, January 25, 2006		Sheet 17 of 34	

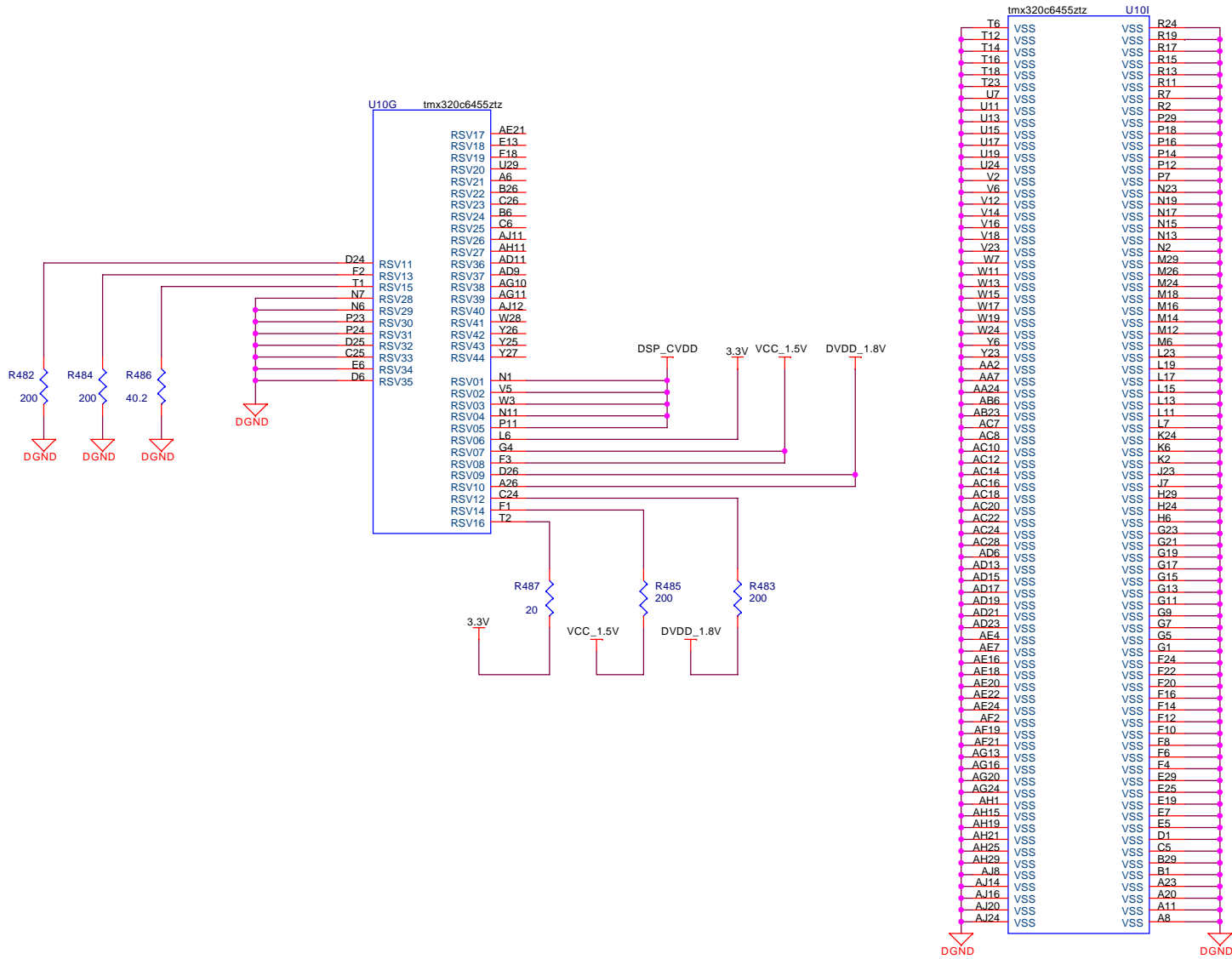

SPECTRUM DIGITAL INCORPORATED			
Title: TMS320C6455 DSK			
Page Contents: 6455 POWER PINS			
Size: B	DWG NO	508552-0001	Revision: A
Date: Wednesday, January 25, 2006	Sheet 18 of		34

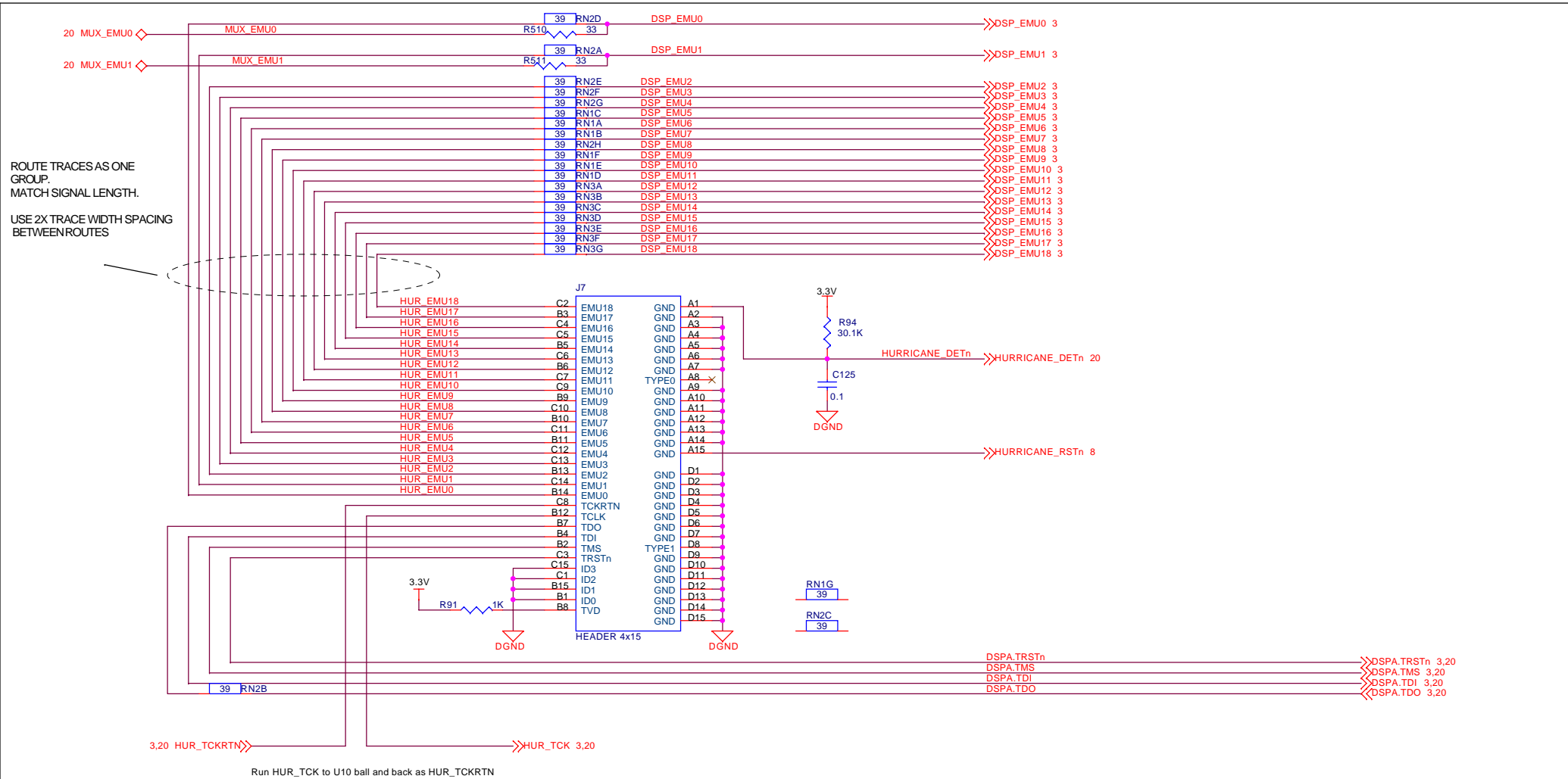

SPECTRUM DIGITAL INCORPORATED			
Title: TMS320C6455 DSK			
Page Contents: Emulation Interface			
Size: B	DWG NO	508552-0001	Revision: A
Date: Wednesday, January 25, 2006	Sheet 19 of		34

DSP JTAG HEADER

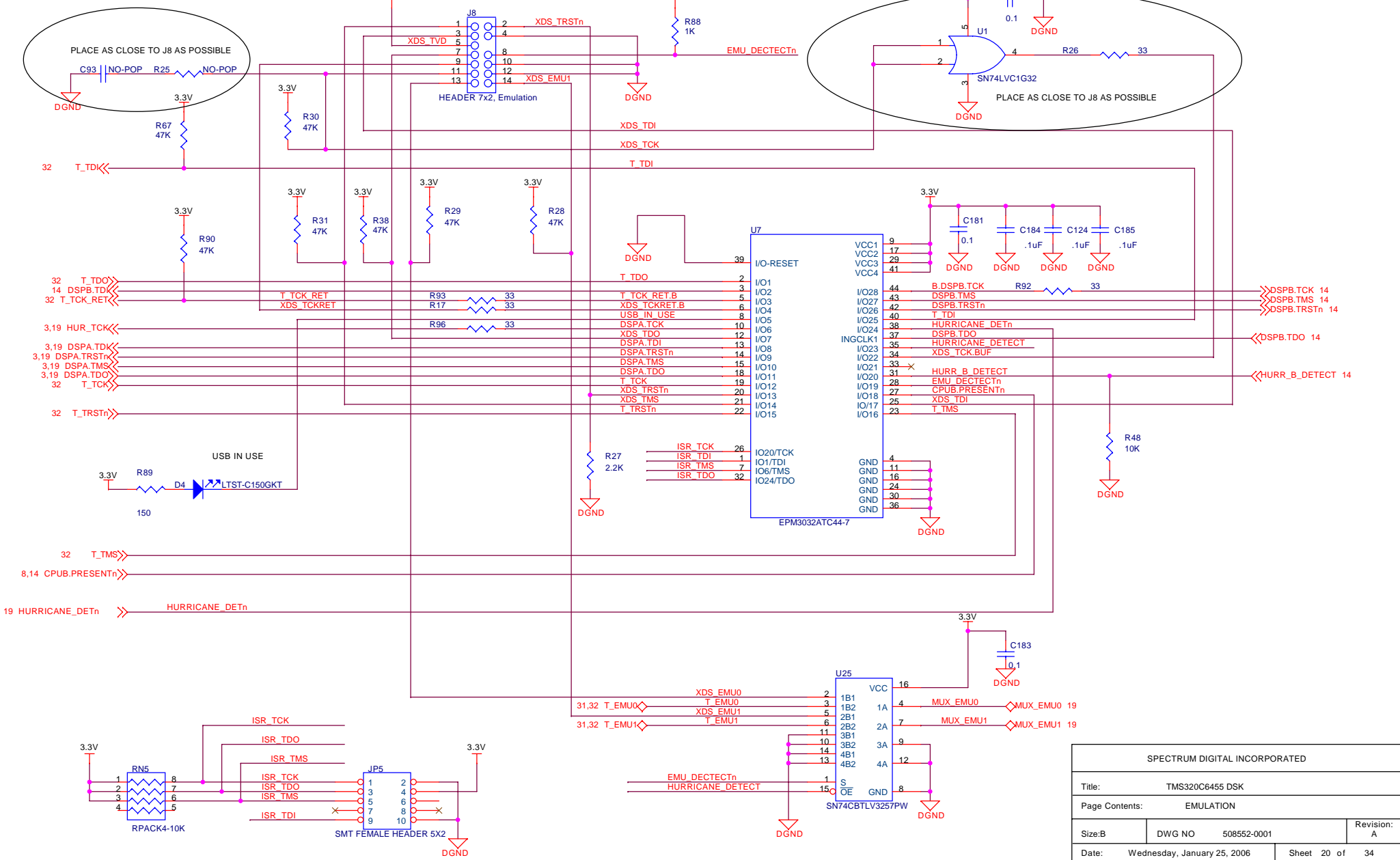

SPECTRUM DIGITAL INCORPORATED			
Title: TMS320C6455 DSK			
Page Contents: EMULATION			
Size: B	DWG NO	508552-0001	Revision: A
Date: Wednesday, January 25, 2006	Sheet	20 of	34

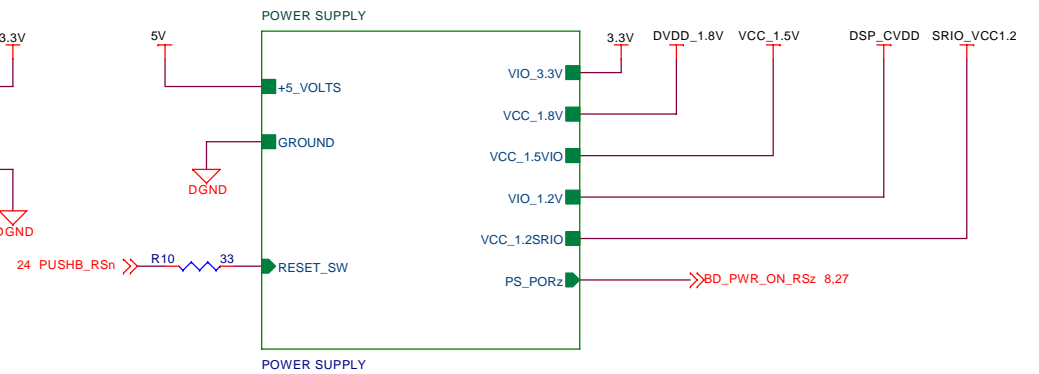
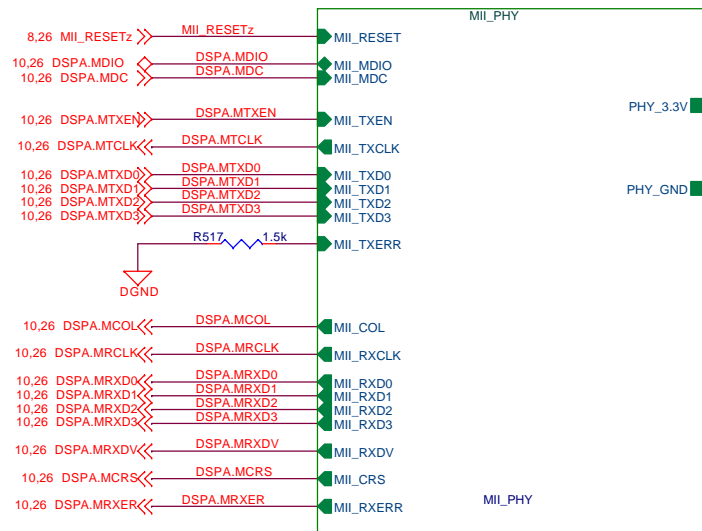
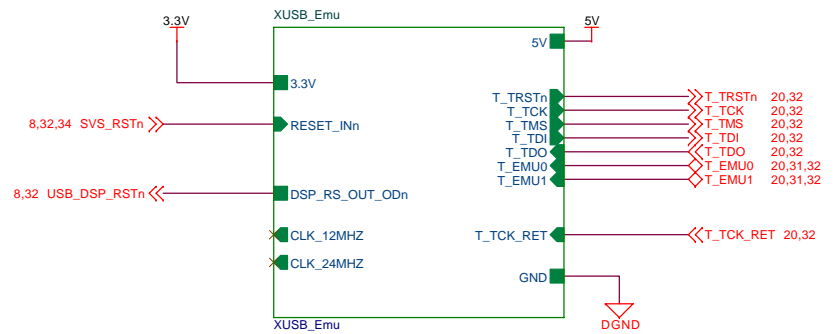
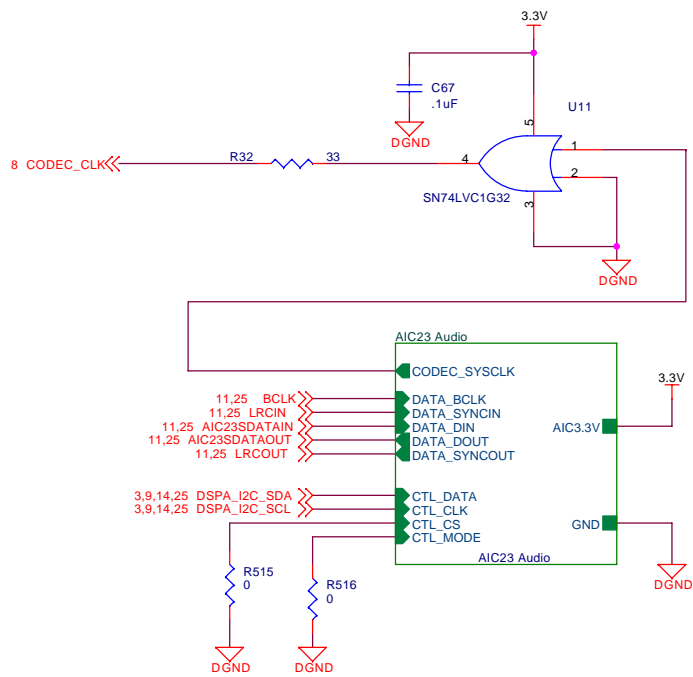

SPECTRUM DIGITAL INCORPORATED			
Title: TMS320C6455 DSK			
Page Contents: Hierarchical Blocks			
Size: B	DWG NO	508552-0001	Revision: A
Date: Wednesday, January 25, 2006	Sheet 21 of 34		

DSP\_CVDD All capacitors on this sheet are decoupling capacitors for the DSP. They should be placed as close as possible to the DSP.

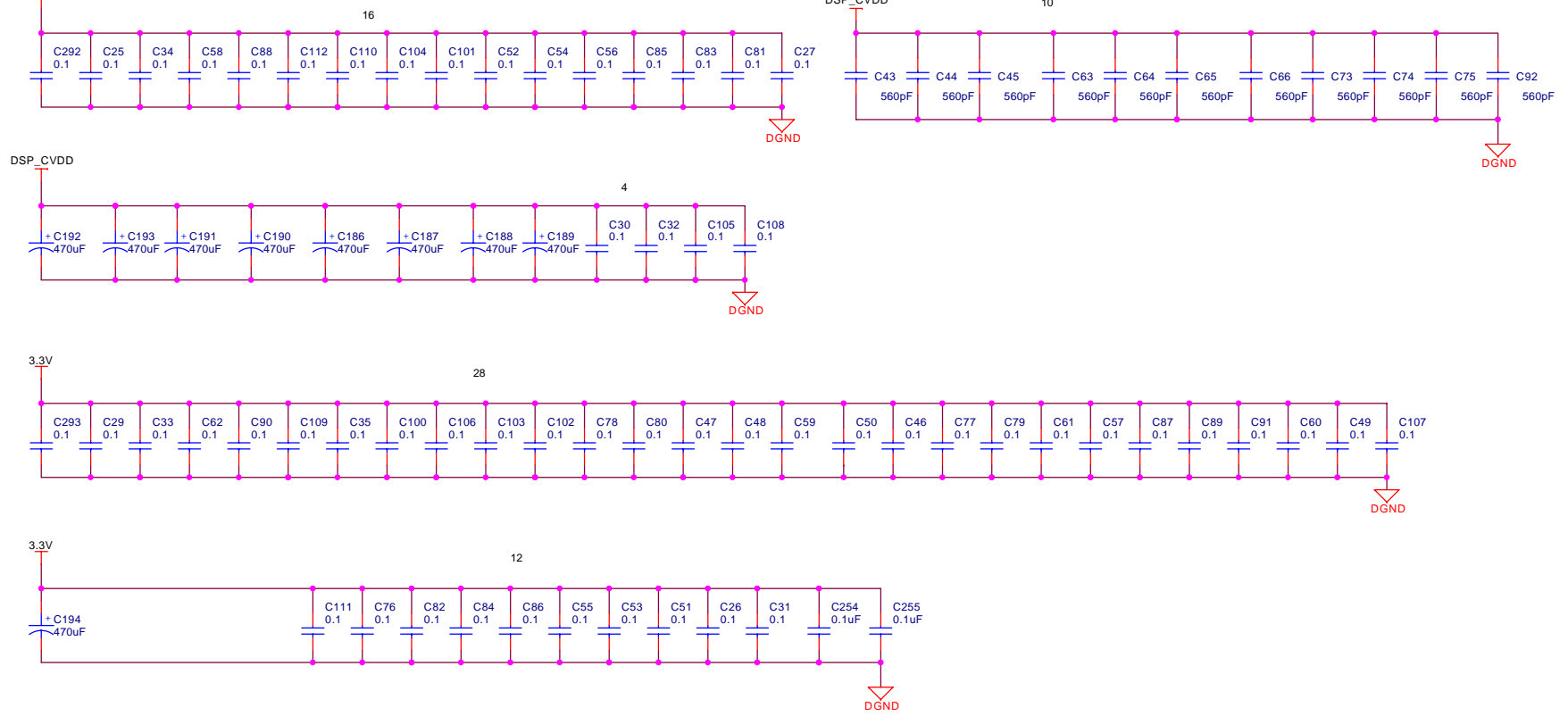

SPECTRUM DIGITAL INCORPORATED		
Title: TMS320C6455 DSK		
Page Contents: Decoupling Capacitors I		
Size: B	DWG NO 508552-0001	Revision: A
Date: Wednesday, January 25, 2006	Sheet 22 of	34

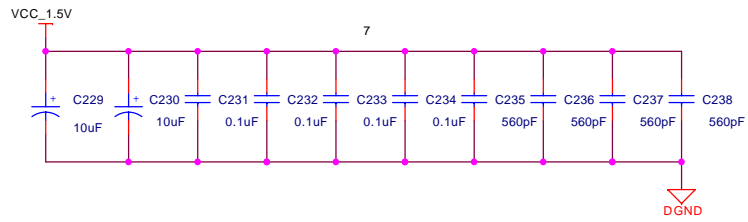
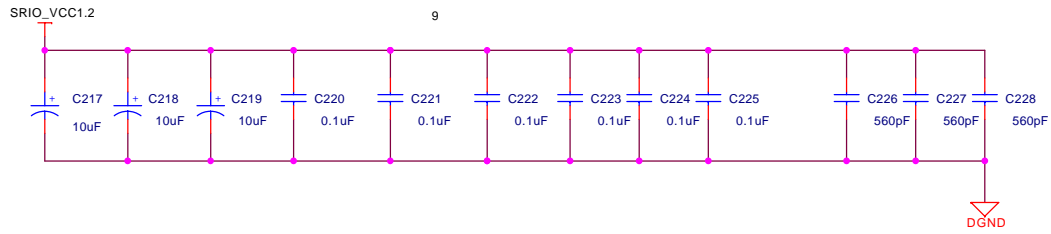
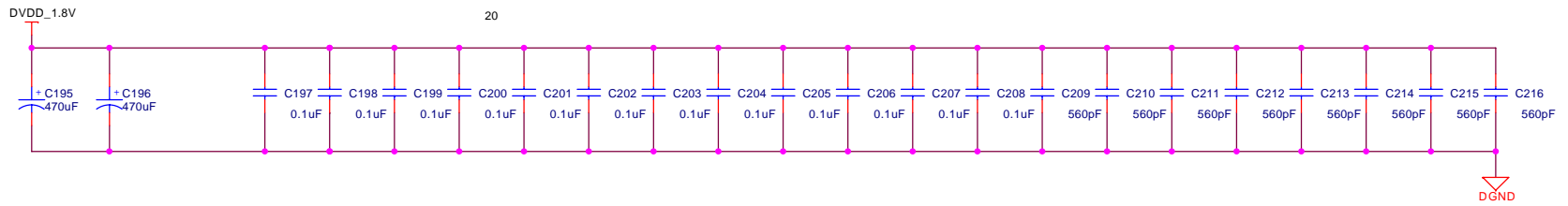

SPECTRUM DIGITAL INCORPORATED			
Title:		TMS320C6455 DSK	
Page Contents:		Decoupling Capacitors II	
Size: B	DWG NO	508552-0001	Revision: A
Date:	Wednesday, January 25, 2006	Sheet 23 of	34

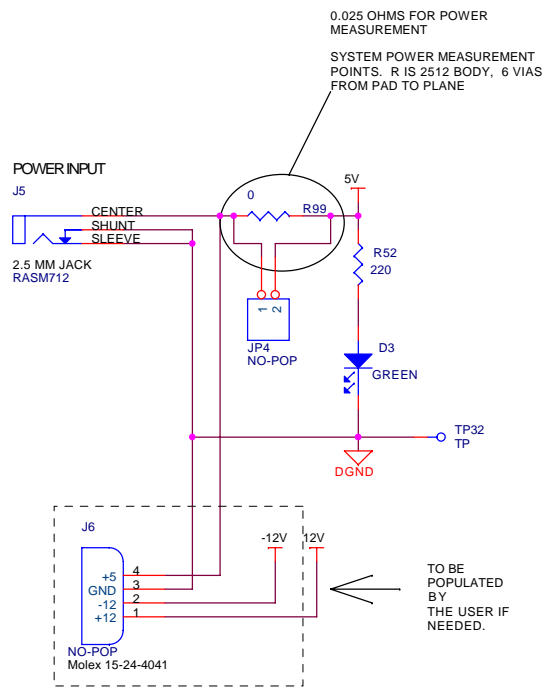

**WARNING:**  
DO NOT SUPPLY POWER TO BOTH POWER CONNECTORS AT THE SAME TIME!

DAUGHTERCARD STANDOFF GROUNDING

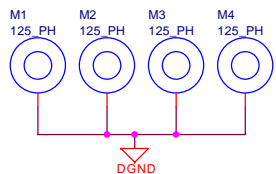

KEEP TRACES A MINIMUM OF 0.070 INCHES FROM THESE HOLES.

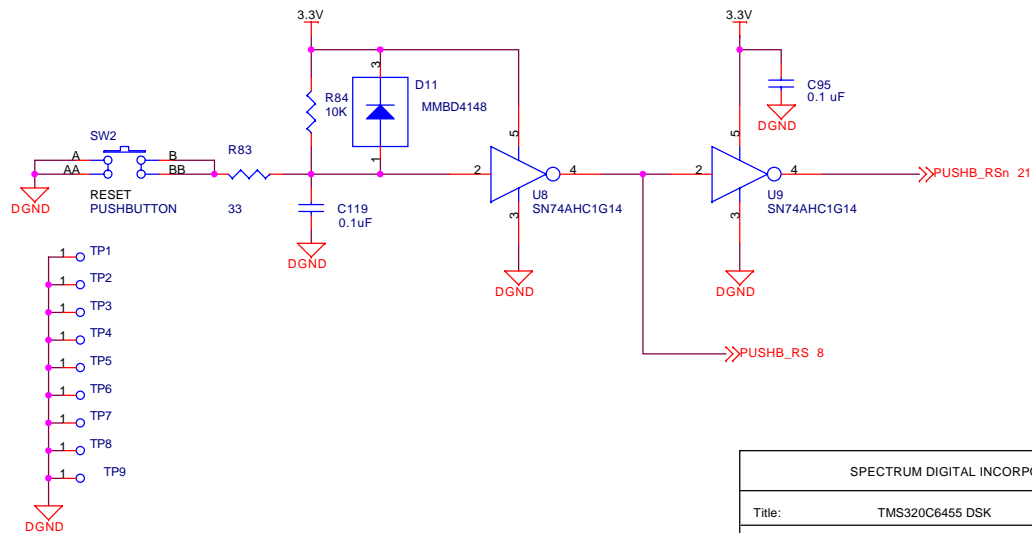

SPECTRUM DIGITAL INCORPORATED		
Title: TMS320C6455 DSK		
Page Contents: Power Input		
Size: B	DWG NO 508552-0001	Revision: A
Date: Wednesday, January 25, 2006	Sheet 24 of	34



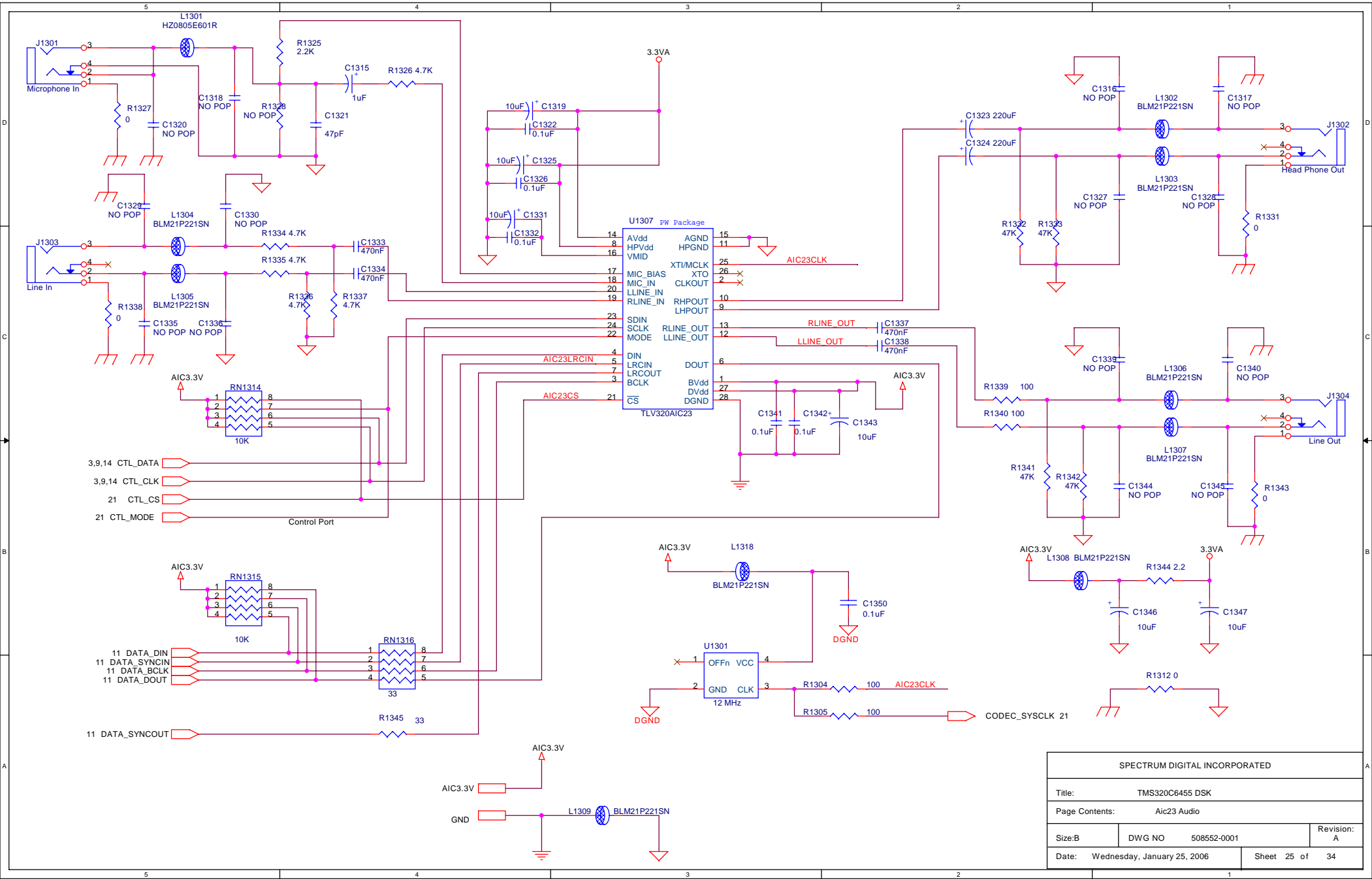

SPECTRUM DIGITAL INCORPORATED			
Title: TMS320C6455 DSK			
Page Contents: Aic23 Audio			
Size: B	DWG NO	508552-0001	Revision: A
Date: Wednesday, January 25, 2006	Sheet 25 of 34		

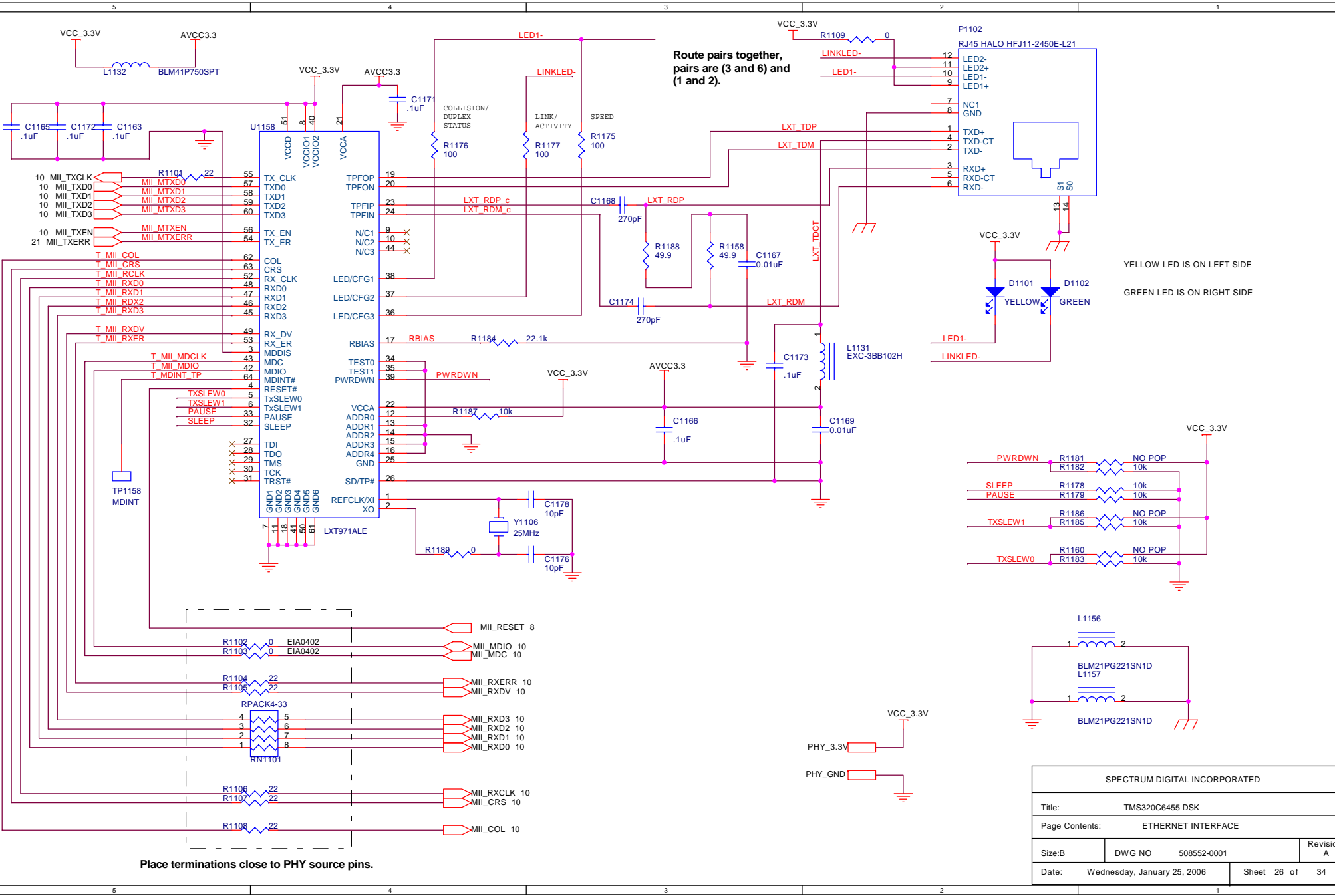

YELLOW LED IS ON LEFT SIDE  
GREEN LED IS ON RIGHT SIDE

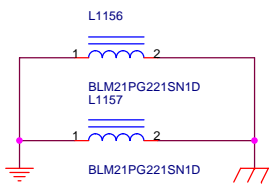
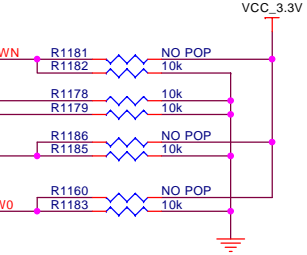

SPECTRUM DIGITAL INCORPORATED			
Title: TMS320C6455 DSK			
Page Contents: ETHERNET INTERFACE			
Size: B	DWG NO: 508552-0001	Revision: A	
Date: Wednesday, January 25, 2006	Sheet 26 of 34		

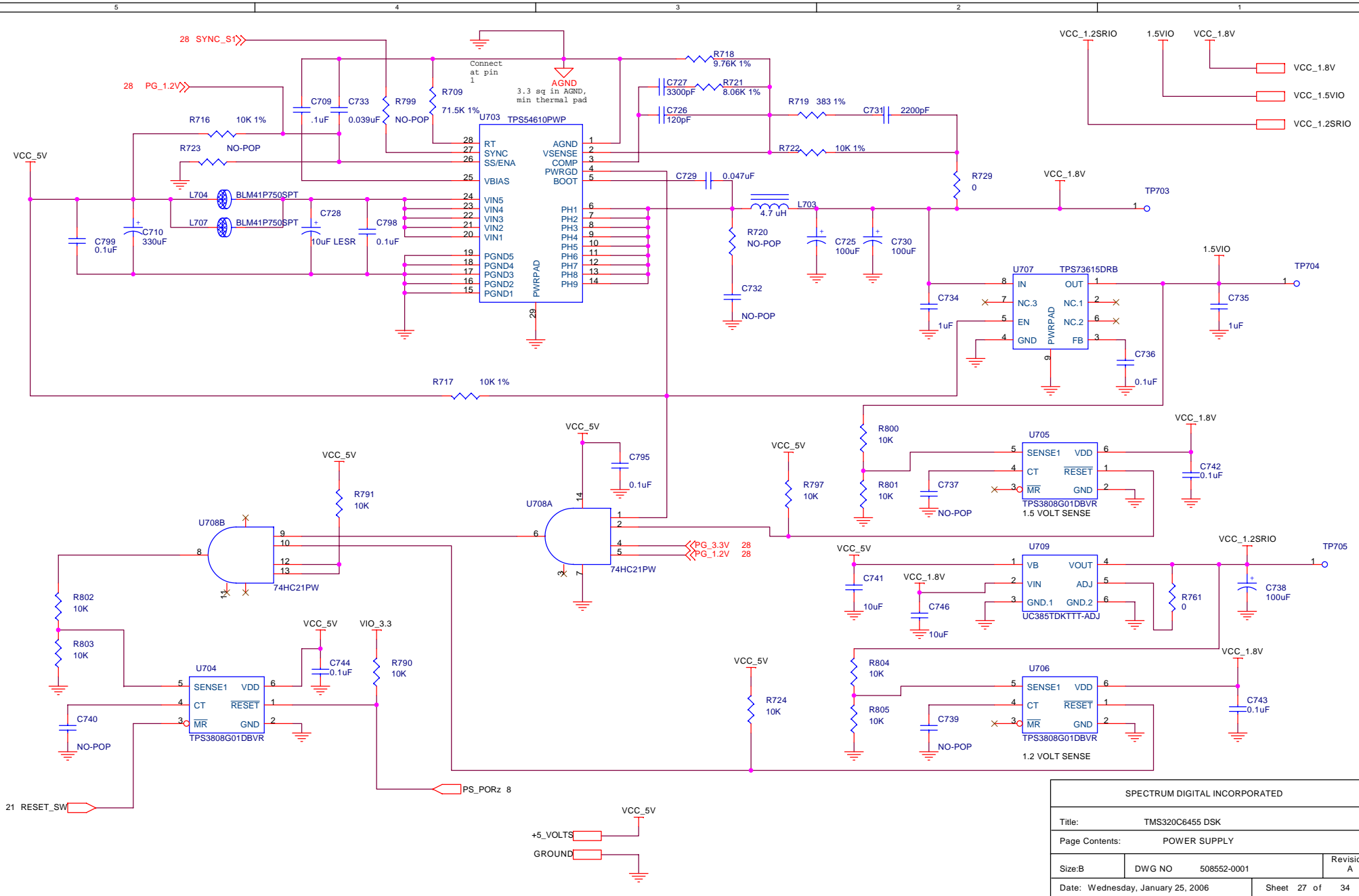

SPECTRUM DIGITAL INCORPORATED			
Title: TMS320C6455 DSK			
Page Contents: POWER SUPPLY			
Size: B	DWG NO	50852-0001	Revision: A
Date: Wednesday, January 25, 2006			Sheet 27 of 34

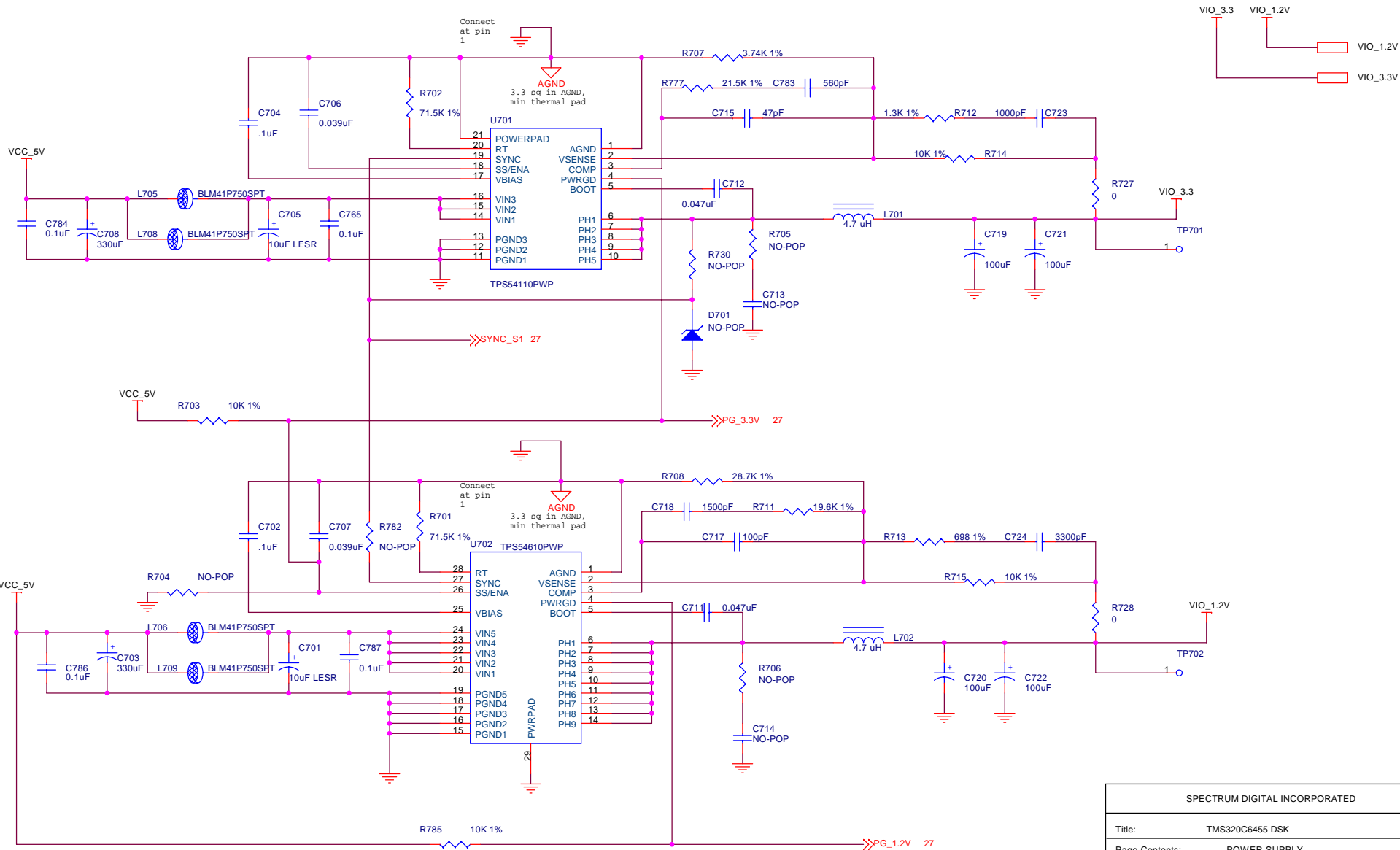

SPECTRUM DIGITAL INCORPORATED			
Title: TMS320C6455 DSK			
Page Contents: POWER SUPPLY			
Size: B	DWG NO	508552-0001	Revision: A
Date: Wednesday, January 25, 2006	Sheet 28 of 34		